

XXX. *Account of the Construction of the New National Standard of Length, and of its principal Copies.* By G. B. AIRY, Esq., *Astronomer Royal.*

Received May 2,—Read June 18, 1857.

IN presenting this Report to the Royal Society, I must solicit their indulgence for many imperfections, arising from the circumstances under which the task of writing it has devolved on me. Through the whole account, I have to record the proceedings of others, and (in a great measure) I have to describe the trains of thought in the minds of others, which have determined those proceedings. The first part of the investigations for restoration of the Standard was made by Mr. F. BAILY; but the largest proportion by very far was effected by my much-valued friend the Rev. R. SHEEPSHANKS. These have successively been removed by death from their labours on the Standards. On the eve of the day on which Mr. SHEEPSHANKS was struck down with mortal disease, he was engaged in micrometrical comparisons of Copies of the Standards; on the day following the deadly stroke, the Royal Assent was given to the Bill for legalizing the Official Standards which he had constructed. Under circumstances like these, it is evident that the documents relating to the final operations must have been left in great confusion. In the earlier portions (the papers relating to which had been, in a measure, roughly brought into order), the difficulty is mainly of another kind. Although from official relation and private friendship I was in constant and unreserved intercourse both with Mr. BAILY and with Mr. SHEEPSHANKS, and though I was cognizant of every step taken, and sometimes examined the apparatus used, yet I never actually made an observation. It is possible therefore that my want of familiarity with the operation may sometimes make my statements imperfect. I trust, however, that in the main my account will be substantially correct.

It will be necessary for me briefly to revise the history of the British Standards for some time anterior to the work which forms the essential subject of this paper.

I propose to divide my Account under the following heads:—

SECTION I.—History of the British and of some Foreign Standards, and of the methods of using them in Base-Measures and Pendulum-Measures, anterior to the legalization of the Imperial Standards by the Act of Parliament of 1824; definition of the Standard of Length by that Act; and provision for its restoration in case of loss.

SECTION II.—Comparisons of Standards, between the passing of the Act of 1824 and the appointment of a Commission for consideration of Standards after the destruction of the Imperial Standard in 1834; with remarks suggested by the advance of collateral theory and experiment in that interval.

MDCCLVII.

4 M

SECTION III.—Appointment of the Treasury Commission of 1838; its proceedings and Report. Appointment of the Treasury Commission of 1843; its proceedings to the death of Mr. BAILY in 1844.

SECTION IV.—Proceedings of the Committee and of Mr. SHEEPSHANKS to June, 1847; construction of new Thermometers; and erection of Comparing Apparatus: description of the Apparatus, and of Mr. SHEEPSHANKS' method of comparing.

SECTION V.—Proceedings of Mr. SHEEPSHANKS to the middle of 1850; preparation of Thermometers; adoption and rejection of "Brass 2" as Basis for the new Standard Yard; adoption and rejection of "Split Plug A"; adoption of "Bronze 12"; experiments on thermometric expansion; comparison of Bronze 12 with several bars; first suspicion of personal equation; rejection of Bronze 12 as Basis, and final adoption of "Bronze 28."

SECTION VI.—Operations of important character to the end of 1853; comparison of a small number of bars with Bronze 28; investigation of Personal Equation; investigation of the effect of Inside or Outside position of the bar; investigation of the relative thermometric expansion of Steel, Wrought Iron, Cast Iron, Copper, and Brass, as compared with Bronze; trial and rejection of BAILY's Apparatus.

SECTION VII.—Comparisons of numerous bars from 1851 to 1855; suspicion of change in Bronze 28; removal of the suspicion; close of the operations on bars defining the Yard by line-measure.

SECTION VIII.—Formation of End-measure Bars.

SECTION IX.—Closing proceedings of Official Character; Extracts from the Final Report of the Commission; Extracts from the Act of Parliament legalizing the New Standard; standard temperatures for the compared bars; disposal of the bars.

SECTION I.—*History of the British and of some Foreign Standards, and of the methods of using them in Base-Measures and Pendulum-Measures, anterior to the legalization of the Imperial Standards by the Act of Parliament of 1824; definition of the Standard of Length by that Act; and provision for its restoration in case of loss.*

The principal materials for the history of the Standards are to be found in the following works:—

Philosophical Transactions, 1742–1743, page 185, &c. Account of the laying down of the measure of 3 feet from the Tower Scale upon the Brass Bar of the Royal Society; and comparison of the Yard with the Half-Toise. [The measure thus laid down was marked E, apparently to denote "English measure" as distinguished from the French measure compared with it.]

Philosophical Transactions, 1742–1743, page 541, &c. Comparisons by GRAHAM (under the superintendence of a Committee of the Royal Society) of the Royal Society's Standard, defined by two points; the Exchequer end-standard, reputed to be the National Standard; the Exchequer standard-beds; the Tower standard-scale; the Guild-hall standard-beds; and the Clock-Makers' standard-bed. The comparisons were made by the use of various kinds of beam-compasses, not described. It seems that, at the end

of these operations, the equivalent of the Exchequer end-standard was laid down on the Royal Society's bar; it is distinguished by the word "Excheq."

Philosophical Transactions, 1768, page 324, &c. In MASKELYNE'S Account of the Maryland degree, there is incidental mention of the comparison of BIRD'S scale with the Royal Society's brass standard, and of BIRD'S scale with the French toise; giving, however, a result for the relation between the Royal Society's Standard and the Toise which differs sensibly from that found by GRAHAM. The process of laying down the value of an end-measure (as the toise) upon a flat surface appears rather rude.

Philosophical Transactions, 1785, page 402, &c. In General ROY'S Account of the measure of the Base on Hounslow Heath, there is mention of the exact agreement (as ascertained from a comparison made by means of RAMSDEN'S beam-compasses) between 3 feet of the Royal Society's or Tower Standard and 3 feet of General ROY'S Scale (a scale originally the property of GRAHAM, which is said to have been divided by BIRD when in the employ of SISSON); and it seems that, in reliance on the uniformity of the division, General ROY then used 40 inches of his scale without any verification of the supplementary 4 inches. There is also a comparison of the Exchequer Yard (as marked on the Royal Society's bar) with the Tower Yard (similarly marked). And there are experiments on the expansions of various metals.

The lengths of the bars and chain to be used in the actual measure of the base were laid down by means of beam-compasses. Omitting the tentative measure by deal rods, the base was measured in two different ways; namely, by glass rods, and by a steel chain. When the glass rods were used, each rod carried a small slider in its end, which was brought into contact with the end of the next rod; the position of the slider, in respect to its own rod, being noted optically with reference to a graduated scale or vernier attached to its own rod. When the chain was used, the position of a mark near each end of the chain was noted optically with reference to marks carried by a plate of metal attached to a fixed post. The same chain was subsequently used for the measure of other bases.

Philosophical Transactions, 1798, page 135, &c. Sir GEORGE SHUCKBURGH describes his Scale as having been laid down by TROUGHTON from a scale of BIRD'S (apparently not from ROY'S scale, which is separately mentioned). When in use, it was fixed by three screws to a block of mahogany. The comparing instrument was not a beam-compass, but a bar carrying adjustable micrometer-microscopes, differing in no important degree from those now employed. This appears to be the first genuine instance of optical comparison; and, from this time, beam-compasses have never been used in England for comparisons. SHUCKBURGH'S Scale was compared with the Royal Society's Tower Standard E, with the Exchequer Yard on the Royal Society's bar, with ROY'S, with two of BIRD'S, with Henry VII. and with Elizabeth's. BIRD'S Standard of 1758, and apparently also that of 1760 (both made for the House of Commons), were transferred to the scale by beam-compasses, and then compared in the same way.

Base du Système Métrique Décimal, tome troisième. About the end of the last cen-

ture and the beginning of the present century (it is difficult to give a better reference, where a work necessarily occupied a long time, and where no dates are affixed to its separate memoirs), the operations were effected for measuring the bases in the French survey, for ascertaining the length of the seconds' pendulum, and for comparing the adopted *mètre* with English measure. For the bases: two separate *toise*-measures were prepared, each equivalent to the *toise* of Peru, being, like the *toise* of Peru, end-measures; but there is no description of the process of verifying the equivalence. Then the two *toise*-measures were placed end to end, so as to give the length of two *toises* from a fixed block; and a slider with a vernier, carried by a second fixed block, was made to touch the extremity nearest to that second block; the same thing was done with the two-*toise* measuring-bars; the difference of the vernier-readings, ascertained optically, gave the difference between the length of the measuring-bar and two *toises*. In the actual use of the measuring-bars, two bars were never permitted to touch: each bar carried a slider or *languette* (as in General ROY's glass rods), and the ultimate reference was to a vernier. An operation, similar to that for the measuring-rods, was used (except that some subsidiary fractions of the *toise* were also employed, the sum of their lengths being ascertained by mechanical contact) for the end-bar which was necessary, in BORDA's method, for measuring the double-seconds' pendulum; the ultimate determination always resting on optical observation of a vernier. For the length of the *mètre* (an end-measure) in comparison with the English scale belonging to Professor PICTET of Geneva, a subsidiary piece bearing a fine line was provided: first, this piece was made to touch a fixed block, and a microscope was adjusted on the line; secondly, the same piece was made to touch one end of the *mètre* while the other end of the *mètre* touched the same block, and another microscope was adjusted on the line; these two microscopes, thus adjusted, were then used to observe the graduations of the scale.

Philosophical Transactions, 1818, page 33, &c. KATER'S Account of experiments for determining the length of the Pendulum vibrating seconds in the latitude of London. The measuring apparatus appears to have been generally similar to Sir GEORGE SHUCKBURGH'S, but with microscopes of greater magnifying power. The beam of mahogany which carried the microscopes was elevated by a foot-screw at each end, for focal adjustment of the microscopes. There is no clear account of the way in which the microscope-frame was moved from one standard to another, or of the way in which standards were brought successively under the microscopes. The distances 0—39·4 and 0—42 on SHUCKBURGH'S scale were compared with 0—39·4 and 0—42 on General ROY'S scale, and a result was obtained differing considerably from SHUCKBURGH'S. BIRD'S standard of 1758 (made for the House of Commons) was also compared with 0—36 of SHUCKBURGH'S. The measure of the distance between the knife-edges of the pendulum (which is an operation whose peculiarities, though in the opposite direction, are similar to those of the comparison of end-standards with line-standards) was effected in two ways: one by introducing supplementary blocks bearing lines, and using the microscopes to observe those lines, both when the blocks touched the knife-edges and when the blocks

touched each other; the other by microscopic view of the edges, alternately with white ground and black ground beneath them. The thermometric expansion of the pendulum-bar was ascertained. The determination of the vibrations of the pendulum was made in Mr. BROWNE'S house, Portland Place, in the atmospheric air; the correction applied, to obtain the number of vibrations which would have been made at the level of the sea, was computed by increasing the number of vibrations in the proportion of the terrestrial radius at the sea to the terrestrial radius at the station; and the correction, to obtain the number of vibrations which would have been made *in vacuo*, was computed by assuming that the only effect of the air was to diminish the attraction of the pendulum in the proportion of the specific gravity of the air to that of the pendulum.

Philosophical Transactions, 1818, page 103, &c. KATER on the length of the French Mètre, as compared with SHUCKBURGH'S scale, 0—39·4. The optical comparison with the Mètre à traits is simple; that of the Mètre à bouts was effected in the same manner as the measure of the pendulum, by the use of supplementary blocks bearing lines.

Philosophical Transactions, 1821, page 75, &c. KATER, Comparison of various British Standards. The standards compared are, the Royal Society's standard (Tower Yard), General ROY'S, SHUCKBURGH'S (0—36 or 0—40), BIRD'S standard of 1760, a standard supposed to represent Colonel LAMBTON'S, and a 40-inch bar, supposed to represent RAMSDEN'S. It appears that the comparing-apparatus was attached to a bar of mahogany, which was to be placed upon the standard to be observed; the standard, apparently, being laid upon a table. In this paper is stated the reason for recommending BIRD'S standard of 1760 for the Imperial Standard; namely, because BIRD'S standard of 1760 agrees closely with SHUCKBURGH'S scale (0—36), with which the pendulum and the mètre had been compared, and of which a facsimile was known to exist at Geneva.

A general view of the relations between the different standards mentioned above will be found in a "Statement" by Mr. SHEEPSHANKS, given in a subsequent part of this paper.

The Bill for giving legal authority to the late Imperial Standards, for providing for their restoration in case of loss or injury, and for settling various other points relating to standards, received the Royal Assent 1824, June 17. It is intituled, "Anno Quinto Georgii IV. Regis, cap. LXXIV., An Act for ascertaining and establishing Uniformity of Weights and Measures." The following Excerpts contain all that relates to the definition and preservation of the Standard of Length:—

Section I. "... Be it enacted ... that from and after the first day of May, One thousand eight hundred and twenty-five, the Straight Line or Distance between the Centres of the Two Points in the Gold Studs in the Straight Brass Rod, now in the Custody of the Clerk of the House of Commons, whereon the Words and Figures 'Standard Yard, 1760,' are engraved, shall be and the same is hereby declared to be the original and genuine Standard of that Measure of Length or lineal Extension called a Yard; and that the same Straight Line or Distance between the Centres of the said Two Points in the said Gold Studs in the said Brass Rod, the Brass being at the temperature of Sixty-two

Degrees by FAHRENHEIT'S Thermometer, shall be and is hereby denominated the 'Imperial Standard Yard.'

Section III. "And whereas it is expedient that the said Standard Yard, if lost, destroyed, defaced, or otherwise injured, should be restored of the same Length, by reference to some invariable natural Standard: And whereas it has been ascertained by the Commissioners appointed by His Majesty to inquire into the subject of Weights and Measures, that the said Yard hereby declared to be the Imperial Standard Yard, when compared with a Pendulum vibrating Seconds of Mean Time in the Latitude of London, in a Vacuum at the Level of the Sea, is in the proportion of Thirty Six Inches to Thirty Nine inches and one thousand three hundred and ninety-three ten-thousandth Parts of an Inch; Be it therefore enacted and declared, That if at any Time hereafter the said Imperial Standard Yard shall be lost, or shall be in any Manner destroyed, defaced, or otherwise injured, it shall and may be restored by making a new Standard Yard, bearing the same Proportion to such Pendulum as aforesaid, as the said Imperial Standard Yard bears to such Pendulum."

SECTION II.—*Comparisons of Standards between the passing of the Act of 1824 and the appointment of a Commission for consideration of Standards after the destruction of the Imperial Standard in 1834; with remarks suggested by the advance of collateral theory and experiment in that interval.*

In the Philosophical Transactions, 1826, Part II., page 1, &c., is KATER'S account of the preparation of the new [Secondary] Standards of Weights and Measures. The only part of this which is important to the present purpose is the following. Four brass bars were prepared, each $1\frac{1}{4}$ inch wide and $\frac{1}{2}$ inch thick, with gold pins bearing points (I refer to the original for the excentric mounting of these points). In the course of the comparisons of these secondary standards with Sir G. SHUCKBURGH'S scale, it was found that discordances to the amount of $\frac{1}{600}$ inch were produced by almost undiscoverable inequalities in the surface of the table on which they were laid. In the new secondary standards, this defect was cured by removing the upper half of the thickness of the bar, in those parts where the defining points are planted, so that the defining points are in reality at the middle of the depth of the bar. But it was impossible to apply this remedy to SHUCKBURGH'S scale; and consequently all measures made with that scale are liable to some uncertainty.

Philosophical Transactions, 1830, page 359, &c. Captain KATER pursues the subject of curvature of bars produced by the inequalities of the supporting surface. He shows that in one instance (DOLLOND'S scale), in which great care had been used, an error of $\frac{1}{900}$ inch had nevertheless been committed. He describes a practical method of testing the planeness of surfaces. He shows that, when the greatest precautions are used, the length of SHUCKBURGH'S scale 0—36 appears sensibly equal to the Imperial Standard. Remarking that, when the supporting surface is nearly plane, a bar of any moderate thickness will accommodate its form to the small inequalities, and the errors of divisions

on the upper surface will be greater for a thick bar than a thin one, he proposes as the best form for a scale a very thin bar carried by a stout one.

Philosophical Transactions, 1831, page 345, &c. Captain KATER gives an account of a Copy of the Imperial Yard made for the Royal Society. The principle of construction is that just described, the thickness of the thin bar being $\frac{7}{100}$ inch. The Copy (0—36) is compared microscopically with the Imperial Standard itself. The Copy and the Imperial Standard were laid upon a marble slab, carefully made plane. The apparatus used is the same as that described in the Philosophical Transactions, 1821.

This is the last of KATER'S papers on the subject of standard-comparisons. The same subjects however had been taken up by others both in England and on the Continent; and results of considerable importance, both as to the methods employed in the practical applications of standards, and as to the evaluations applicable to the perpetuation of the Standard, had been obtained. The following account of these will probably suffice.

In various parts of Europe, bases have been measured by the use of end-measures. But in every instance, the principle has been adopted of not permitting the successive measuring-rods to come in contact, but of measuring the interval between their ends. In some instances, this has been done by inserting a glass wedge; in others, by use of a *fühl-hebel* or multiplying-lever: in all cases, reference is ultimately made in some degree to optical observation.

In the extension of the British survey, bases have been measured with a new apparatus: of which the following peculiarities deserve notice. First, the Ordnance Survey Office have used, as standards of reference for field-measures, two 10-foot iron bars; each bar carrying points for microscopic observation on surfaces sunk to the level of the middle of the bar's depth; and supported, not on a table or on immoveable supports, but on two rollers placed each at the distance of one-fourth of the bar's length from one end; the bar being so fixed at the middle as to prevent it from running endways. Secondly, that the measuring-bars (which were so constructed as to be sensibly invariable in length under different temperatures) carried points for microscopic observation; and the space between the point on the following end of one bar and that on the preceding end of the next bar was measured by means of a pair of microscopes firmly connected, but so arranged that the distance between their focal points is sensibly independent of changes of temperature. In this apparatus therefore the measure is purely optical without any reference whatever to contact.

Subsequently to the introduction of this apparatus, new standard-bars and scales were formed (of considerable importance in the present inquiry) and were extensively compared. First, two iron 3-foot bars marked 1A and 2A, bearing points at the middle of the depth of the bars, and usually supported on semicircular blocks of brass, each placed at one-fourth of the bar's length from one end, were prepared for the Department of the Ordnance Survey. These bars were compared immediately with the Imperial Standard in the year 1834: the comparisons were not published till the printing (in 1847) of the Account of the Measurement of the Lough Foyle Base (see pages 82 and [28] of that

work), but were known (by the friendly communication of the Director and Officers of the Survey) to the persons engaged on the National Standards. Secondly, a tubular scale 5 feet long, was prepared in the year 1833 for the Royal Astronomical Society, and was compared with numerous standards in the year 1834. I must refer to Mr. BAILY'S account of the comparisons in the Memoirs of the Royal Astronomical Society, vol. ix. : but I may extract the following points. After experimental proof of the injurious effects of resting the tube upon two fixed supports, it was placed upon two rollers, at the quarter-length distance from each end. A frame carrying two microscopes was prepared, for observing the divisions of the tubular scale and those of other bars or scales which might be brought for comparison. A view of this is given in page 75 of the account to which I refer: its structure was very weak. The scale in question was compared with several similar tubular scales, and with the Imperial Standard. Moreover, lines for observation were cut at the distance 60 inches on four sides of the tube, and their intervals were compared. It is impossible by extracts to do justice to this paper; I can only remark that any person who wishes to become acquainted with the state of the Imperial Standard and the impossibility of observing it accurately, with the errors of comparisons before 1800 and the inaccuracies after that time, must study this memoir. At the same time I remark, that, as will appear in the course of the present communication, on some important points there was still room for additional exactness.

The length of the seconds' pendulum was measured by BESSEL in 1835 (I shall allude shortly to an important correction previously made by him in the theory of the pendulum). The method which he used was that of observing the vibrations of two pendulums whose difference of length is exactly equal to the standard (one toise). This is, so far as I am aware, the only instance in which an end-standard has been used for a physical measure without the essential aid of optical apparatus.

In the same year, BESSEL constructed the new Prussian Standard of three Prussian feet. This is an end-standard; the bar being of steel, and the ends being of sapphire. A line-standard had been made in 1816, but BESSEL'S confidence in line-measures appears to have been shaken, partly by KATER'S discovery of the effects of trifling flexure, mentioned above (though he acknowledges that the means of obviating the injurious effect is extremely simple), and partly by BAILY'S remark on the "personal equation" or difference in the way in which different persons observed the large and distorted point on GRAHAM'S 1760 bar. Moreover, the law of Prussia defined the Prussian Foot in terms of the French Toise, which is represented by an end-standard. This circumstance, in combination with the application of the toise to the indirect measure of the pendulum mentioned above, appears sufficient justification of the introduction of an end-standard.

These are the principal points in the history of standards bearing upon the accuracy of comparison and application of standards. But a discovery had been made in a related subject, which bears importantly upon the legal provision for the restoration of the British Standard in case of its loss. BESSEL discovered that the correction which had been usually applied, and which was applied by KATER, for reducing the vibrations of a

pendulum as observed in atmospheric air to the vibrations in vacuum, ought to be greatly increased. SABINE immediately repeated these experiments, with special reference to the form of pendulums which had been usually employed in England; and after him, BAILY extended the experiments to pendulums of various forms*. The result for British pendulums is, that KATER'S correction ought to have been multiplied by 1.655 nearly. The corresponding error in the length of the yard-standard is a quantity very conspicuous to the naked eye.

There is also great doubt on the propriety of the reduction to the level of the sea.

It may not be out of place to anticipate here an investigation begun by myself in 1843 and completed in 1844 or 1845 (sufficiently early to be used in the observations hereafter to be mentioned), and printed in the Royal Astronomical Society's Memoirs, vol. xv. It relates to the value of the intervals (supposed equal) which ought to exist between different supports of a bar, each support exerting the same vertical pressure upwards, in order that the interval between two points upon the surface of the bar may not be altered by the flexure. The resulting interval of supports = $\frac{\text{length of bar}}{\sqrt{(n^2-1)}}$, where n is the number of supports. It is easily seen that the arrangement of levers by which equal pressures upwards may be exerted at four or eight points, is very simple.

I believe that the matters which I have cited will give a correct idea of the advances made in the science of standards since the Act of 1824. It had been shown that it was imprudent in any case to trust to points or lines traced on the surface of a bar, and therefore for delicate purposes, supposing the standard to be a line-measure, only two lines or points ought to be used, sunk to the middle of the bar's thickness. It had been shown that it was imprudent to lay the bar upon a table or upon fixed supports of any kind, and therefore the bar must be stiff enough to bear to be supported upon a few points at which rollers could be conveniently applied. It had been shown that the physical reference provided in the Act of Parliament of 1824 was erroneous in one particular and doubtful in another; and, as it seemed likely that similar uncertainties might be found in any other physical reference, the conviction was gradually rising that it would be better to trust, for restoration, to attested copies of the Standard. The question of the propriety of adopting line-measure or end-measure for the National Standard, which in this country had been practically decided (without a single opposing instance as regarded accurate standards) in favour of line-measure, had again been raised by BESSEL'S adoption of end-measure.

On 1834, October 16, occurred the fire at the Houses of Parliament, in which the Standards were destroyed. The bar of 1760 was recovered, but one of its gold pins bearing a point was melted out, and the bar was otherwise injured.

On 1838, May 11, the Right Honourable T. SPRING RICE (now Lord MONTEAGLE), Chancellor of the Exchequer, requested a Committee to consider and report upon the course which under all circumstances it would be best to follow.

* See the Philosophical Transactions, 1829 and 1832.

SECTION III.—*Appointment of the Treasury Commission of 1838: its proceedings and Report. Appointment of the Treasury Commission of 1843: its proceedings to the death of Mr. BAILY in 1844.*

The letter of the Chancellor of the Exchequer constituting the Standard Commission was in the following terms:—

“Downing Street, May 11, 1838.

“SIR,—The attention of Her Majesty's Government has lately been directed to the necessity of determining a standard weight and measure to replace those which were destroyed by the burning of the Houses of Parliament.

“Before any steps are taken in this important matter, I am desirous of availing myself of the opinion of yourself and other competent persons; and I therefore request that you will have the goodness to communicate with the gentlemen named in the margin (Mr. F. BAILY, Mr. J. D. BETHUNE, Mr. DAVIES GILBERT, Mr. J. S. LEFEVRE, Mr. J. W. LUBBOCK, Rev. G. PEACOCK, Rev. R. SHEEPSHANKS), to each of whom a copy of this letter will be sent, and report to me the course which you shall agree in thinking best to be pursued under the peculiar circumstances of the case.

“I have, &c.,

“T. SPRING RICE.”

“*To the Astronomer Royal.*”

The objects of this Commission were evidently intended to be of preliminary character, and therefore indefinite and wide. It was proper, for instance, to consider, not only whether the Parliamentary enactment for the restoration of the Standard of Length ought to be repealed, but also whether a new fundamental measure or a new scale of measures, implying a National Standard of different length from the old one, should be recommended. The Commission collected much evidence, and digested it under the heads

- A. Basis (arbitrary or natural) of the system of Standards.
- B. Construction of Primary Standards.
- C. Means of restoring the Standards.
- D. Expediency of preserving one measure, &c. unaltered.
- E. Change of Scale of Weights and Measures.
- F. Alteration of the Land-Chain and the Mile.
- G. Abolition of Troy Weight.
- H. Introduction of Decimal Scale.
- I. Assimilation to the Scales of other Countries.
- K. Construction of Secondary Standards.
- L. Construction of Local Standards.
- M, N, O relate to legal and practical details.

On 1841, December 21, the Commission presented their Report, of which the following are the parts which relate to the Standard of Length.

Chapter I. describes the ruined state of the Imperial Standards.

Chapter II. With respect to the definition, we are of opinion that the definition

contained in the Act 5 Geo. IV. cap. 74, sect. 1, ... by which the standard yard ... is declared to be a certain brass rod therein specified, is the best which it is possible to adopt. With respect to the provisions for restoration, we are not prepared to recommend the adoption of that prescribed by section 3 of the same Act, whereby it is directed that, in case of the loss of the metallic standard above-mentioned, the yard shall be restored by taking the length which shall bear a certain proportion to the length of the pendulum, vibrating seconds of mean time, in the latitude of London, in a vacuum, at the level of the sea. Since the passing of the said Act, it has been ascertained that several elements of reduction of the pendulum-experiments therein referred to are doubtful or erroneous: thus it was shown by Dr. YOUNG, *Philosophical Transactions*, 1819, that the reduction to the level of the sea was doubtful; by BESSEL, *Astron. Nachr.*, No. 128, and by BAILY, *Philosophical Transactions*, 1832*, that the reduction for the weight of air was erroneous; by BAILY, *Philosophical Transactions*, 1832, that the specific gravity of the pendulum was erroneously estimated, and that the faults of the agate planes introduced some degree of doubt; by KATER, *Philosophical Transactions*, 1830, and by BAILY, *Astronomical Society Memoirs*, vol. ix., that very sensible errors were introduced in the operation of comparing the length of the pendulum with SHUCKBURGH'S scale, used as the representative of the legal standard. It is evident, therefore, that the course prescribed by the Act would not necessarily reproduce the length of the original yard. Several measures, however, exist, which were most accurately compared with the former standard yard (in particular the Royal Astronomical Society's Scale, described in their *Memoirs*, vol. ix., and the iron bars belonging to the Board of Ordnance, in the custody of Colonel COLBY,) ... and by the use of these the values of the original standards can be respectively restored without sensible error. And we are fully persuaded that, with reasonable precautions, it will always be possible to provide for the accurate restoration of standards, by means of material copies which have been carefully compared with them, more securely than by reference to any experiments referring to natural constants. With these views we recommend the following course:—

1. That so much of the Act 5th Geo. IV. cap. 74, as provides for the restoration of the standards in the manner therein mentioned, be repealed; and that the standard of length be defined, in subsequent enactments of the legislature, either by the whole length of a certain piece of metal or other durable substance, supported in a certain manner, at a certain temperature (to the construction and dimensions of which, further allusion will be made in this Report); or by the distance between two points or lines engraved upon the surface of a certain piece of metal or other durable substance, supported in a certain manner, at a certain temperature; but that the standard be in no way defined by reference to any natural basis, such as the length of a degree of meridian on the earth's surface in an assigned latitude, or the length of the pendulum vibrating seconds in a specified place.

* This reference appears to have been transcribed by mistake from that which follows. It ought to have been SABINE, *Philosophical Transactions*, 1829.

5. That four sets of copies (to be denominated the Parliamentary Copies) of the standards of length and weight be made, in all respects similar to the legal standards of length and weight (which are hereinafter denominated the Parliamentary Standards), and as nearly as possible equivalent to them; their difference from the Parliamentary Standards, if appreciable, being carefully ascertained; and that the several Parliamentary Copies be distinguished by proper marks.

6. That one set of the Parliamentary Copies be enclosed in a case hermetically sealed, and imbedded within the masonry of some public building; and that the place in which it is enclosed be pointed out by a conspicuous inscription on the outside; and that this set of Copies be not disturbed, without the sanction of an Act of Parliament.

17. That the superintendence of the construction of the new Parliamentary Standards be entrusted to a committee of scientific men, to be named by Her Majesty, subject to the general instructions which follow.

18. That the Superintending Committee be instructed to combine, in the way which may appear most advantageous, the evidence afforded by the Royal Astronomical Society's scale, by the Royal Society's scale No. 46, and by the 3-foot bars of the Ordnance Survey; and by the use of these to construct a new standard of length, representing as nearly as possible the same measure as the lost standard.

19. That the whole length of the bar, or the distance between two points or lines marked upon it, be adopted as the Parliamentary Standard of length; and that the bar bear no other divisions.

20. That the question of adopting the whole length or the distance between two points or lines, as well as the choice of material, and the general construction of the standard-bar, be left to the decision of the Superintending Committee.

21. That the length of the new Parliamentary Standard be one yard; there appearing to us no sufficient reason for departing from the length hitherto adopted for the standard.

22. That the thermometrical expansion of the standard-bar be determined by actual experiment on it.

23. That the temperature at which the length defined by the standard-bar represents the yard be fixed by the Superintending Committee.

The Report contains other recommendations, relating to periodical comparisons of the Standards and Copies, collection of ancient standards, &c., but it does not appear necessary to allude further to these in the present memoir.

This Report was presented to the Chancellor of the Exchequer, and after a time the following authority for further proceedings was received:—

“Treasury Minute, dated 20th June, 1843.

“My Lords read the Report of the Commissioners for the restoration of the Standards of Weight and Measure, presented to both Houses of Parliament in 1841, and advert more particularly to the recommendation of the Commission, that a committee of scientific men should be appointed to superintend the construction of the new Parliamentary Standards.

“It appears to my Lords to be very desirable that the gentlemen who acted as Commissioners for the Restoration of the Standards should afford their assistance, if they can be prevailed upon to do so, in directing the executive measures necessary for carrying out the recommendations contained in the report now before my Lords.

“Their Lordships therefore deem it expedient to propose to the undermentioned noblemen and gentlemen to undertake the task; viz.—

The ASTRONOMER ROYAL,
 The Marquis of NORTHAMPTON,
 The Lord WROTTESLEY,
 F. BAILY, Esq.,
 J. E. D. BETHUNE, Esq.
 J. G. S. LEFEVRE, Esq.,
 Sir J. W. LUBBOCK, Bart.,
 The Rev. G. PEACOCK, Dean of Ely,
 The Rev. R. SHEEPHANKS,
 Sir J. F. W. HERSCHEL, Bart., and
 Professor MILLER.”

(The name of the Earl of ROSSE was subsequently added.)

Before this time, the Lords of the Treasury had ascertained that it would be agreeable to the members of the Committee named, that the work of Standards of Length should be entrusted to Mr. BAILY, and that of Standards of Weight to Professor MILLER, and had engaged the services of those gentlemen; Mr. BAILY declining to accept remuneration.

The first meeting of the Committee was held on 1843, July 11, when it was reported that the following measures were collected:—

The scale of the Royal Society, No. 46.
 The scale of the Royal Astronomical Society.
 The two 3-foot bars of the Ordnance Survey.

It was resolved (provisionally), That the Parliamentary Standard of Length be a measure *à traits*; that the material be bell-metal (including any variations in the proportion of tin, &c.) or steel, as Mr. BAILY should think best; that the Standard be about an inch square; that its ends be notched away to half its thickness, and that the marks defining the standard length be made upon pins (if necessary) inserted in the surface parallel to the length of the bar thus exposed; that the marks be adjusted to represent the length of one yard at the temperature of 61° or 62°, as nearly as possible; and that the bar be supported by a series of supports distributed over many points through its whole length, so as to destroy the effect of gravity in bending the bar as completely as possible.

It was, I believe, at this meeting, that the formation of the planes for receiving the defining-marks, by sinking wells to half the thickness of the bar instead of cutting the bar in the form of a notch, was sanctioned, but not by formal resolution.

Mr. BAILY proceeded immediately to make experiments on different materials, as applicable to the formation of Standard Bars. Mr. BAILY, I believe, entertained with me the opinion that, if a bell-metal or gun-metal mixture could be found possessing the properties most essential to the present use of a standard bar, it would be greatly preferable to iron or steel for the construction of a standard intended to last through many ages, by reason of its almost perfect immunity from rust. Therefore, although a bar of steel was prepared at the same time as bars of different compositions of gun-metal, and though it is expressly recorded that experiments were made on it, they do not appear to have been made with the same detail as those on gun-metal bars; at least I find no such details in Mr. BAILY'S Manuscript Book or in his correspondence with me. The entries most worthy of note are the following:—

“1843, August 18.—Mr. SIMMS having procured the five* bars before mentioned [all 40 inches long and 1 inch square], and also a brass tube, I this day attended at his house to make experiments on the curvature of the same, by attaching various weights to the centre, when the bar was supported at the ends. The steel bar was the first tried.

“August 21.—Attended again at Mr. SIMMS'S, and experimented on the brass bar No. 1.

“August 23.—Experimented on the gun-metal bar No. 2.

“August 24.—Experimented on the gun-metal bar No. 3.

“August 25.—Experimented on the gun-metal bar No. 4.

“August 26.—Experimented on the brass tube, similar to Ast. Soc. Standard.

[It appears, from a letter of Mr. BAILY to myself, dated 1843, August 30, that the greatest weight was 21 lbs.]

“August 31.—Let fall all the brass bars from an elevation of 5 feet on a stone pavement. The gun-metal No. 4 was the least affected, but none of them broke.

“September 9.—Loaded No. 4 at the centre with $\frac{1}{2}$ cwt. weights till the total weight was $5\frac{1}{2}$ cwt., when it snapped with a loud report, like a loud shrill bell violently struck. It was very elastic whilst the weights were being applied. [The bar was evidently showing signs of elasticity during the operation, and sprung up and down like a piece of whalebone; and I really believe that the bar would have resumed its straightness, if the weights had been removed immediately before the last was put into the scale. The pieces, on breaking, sprung up, by reason of their elastic force. The fracture was precisely in the middle, which indicates the soundness and uniformity of the structure, and the granulation is very good. As the weight of the scale, ropes, and iron hook, must have exceeded $\frac{1}{2}$ cwt., the total weight applied was above 670 lbs.—*Letter to myself, dated 1843, September 11.*”]

* MESSRS. MAUDSLAYS and FIELD, by whom the brass and gun-metal bars were cast, have favoured me with the particulars of their composition. They are as follows:—

- No. 1. Copper 32, zinc 12.
- No. 2. Copper 32, tin 1, zinc 3.
- No. 3. Copper 32, tin 3, zinc 2.
- No. 4. Copper 32, tin 5, zinc 2.

The following is extracted from the Minutes of the Meeting of the Committee, 1843, November 10:—"Mr. BAILY reported that he had made trials of various materials for the Standards of Length; namely, steel, brass, and four kinds of gun-metal. One of the gun-metals, composed of 28 lbs. of copper to 4 lbs. 6 oz. of tin [I believe that which is called No. 4 above, though the statement of the component parts is not quite correct], was very brittle, and the bar had been broken in his experiments. The next [No. 3 I believe], composed of 28 lbs. of copper to 2 lbs. 10 oz. of tin, was very elastic, returning perfectly to its original state after having been sensibly bent by heavy weights; and on being chipped, was found by Mr. BAILY and Mr. DONKIN to be much less brittle than the former. Mr. BAILY intimated that he was disposed to recommend the use of this metal."

The following is extracted from Mr. BAILY'S MS. book:—"November 13.—Attended at Mr. SIMMS'S, and submitted the gun-metal bar No. 3 to the same process as on September 9. After putting $5\frac{1}{2}$ cwt. in the scale, the bar was so much bent that it slipped off the support; and on measuring the curvature it was 4.1 inches. I then submitted a copper bar of the same dimensions to a similar process. After putting 4 cwt. into the scale, the bar was bent 3.8 inches."

The experiment is farther explained by the following extract of a letter to myself, dated 1843, November 15:—"I have tried the effect of applying a great weight to the bar which Mr. DONKIN and myself seemed to prefer to that which had been previously tried. The result however has completely altered my opinion. I found that $5\frac{1}{2}$ cwt. bent the bar so much that it slipped off the support. The curvature (or versed sine) was 4.1 inches, which was permanent, and did not recover itself. It certainly was a tougher metal, which was what Mr. DONKIN, and I believe all artists or mechanics, delight in. But this is not the quality that suits us; and I therefore prefer the more brittle metal, which was elastic as long as it would hold together, and would rather break than bend."

Mr. BAILY adds: "Instead of having the ends of the bar cut off as a notch in KATER'S mode, I propose to have a cylindrical hole drilled, $\frac{3}{8}$ ths of an inch in diameter, half-way through the bar. I find that I have as much light as on the open surface, and my objection to weakening the bar is thereby removed. Mr. SIMMS says he can cut as fine a line at the bottom of this well, as he can on a plane surface. He is trying his hand at this experiment, and if it succeeds, I trust there will not be any objection to the method. It will be much safer as to strength, and the lines will be well protected."

Mr. BAILY'S illness and death prevented him from laying these results before the Committee, but I communicated them at the meeting of 1844, November 30. The gun-metal No. 4 has been adopted in all the standard bars subsequently made (except where a difference is specially mentioned), and it appears to be an admirable alloy for all similar purposes. Its exact composition is—

Copper	16
Tin	$2\frac{1}{2}$
Zinc	1

as stated by Mr. SIMMS, who superintended the construction, and by Messrs. MAUDSLAYS, who performed the actual casting. The construction of bars with well-holes for the defining marks has also been adopted in all the subsequent instances; but the bars have been reduced to the length of 37 inches by Mr. BAILY, and 38 inches by Mr. SHEEP-SHANKS.

After the first experiments applying to the fitness of metals, Mr. BAILY proceeded with experiments in verification of some made by Captain KATER on the influence of small inequalities of the surface supporting a bar. The experiments were made at his own house, No. 37, Tavistock Place. The bar of metal No. 3 was notched to half its depth at each end, and at each end there was cut a line for microscopic observation on the upper surface (the interval of the two lines being 38 inches), and a line for microscopic observation on the surface at mid-depth (the interval of the two being 39 inches). The bar was laid upon a very even bar (whose section is T) in the comparing-apparatus of the Royal Astronomical Society, and the microscopes were adjusted sometimes to one pair of lines, sometimes to the other. At the commencement of this and of other series of experiments, it is noted that the microscopes were made parallel. The value of one division of the micrometer = 0.00005 inch. A wire, or pair of wires, described as "No. 2 brass wire in my Cavendish experiment," was placed in different positions under the bar. [Only one brass wire is mentioned in the 'Account of the Cavendish Experiment,' page 29; its thickness was 0.0134 inch.] Sometimes the bar was placed on rollers. The following are variations in the measure of the intervals of the lines, under different circumstances. Each number is the mean of several experiments.

1843.			div.
Sept. 14.	Lines on upper surface	Bar lying flat	0.00
		Wires under the ends	- 14.35
		Wires under the middle	+ 6.05
	Lines on surface at mid-depth...	Bar lying flat	0.00
		Wires under the ends	+ 2.50
		Wires under the middle	- 2.50
Sept. 15.	Lines on upper surface	Rollers 8 inches from centre ...	+ 24.68
		Rollers 10 inches from centre ...	+ 21.92
		Rollers 12 inches from centre ...	+ 17.94
		Rollers 6 inches from centre ...	+ 25.12
		Rollers 10 inches from centre ...	+ 19.76
		Rollers 14 inches from centre ...	+ 12.80
Sept. 16.	Lines on upper surface	Bar lying flat	0.00
		Wires 8 inches from centre	+ 6.65
		Wires 10 inches from centre	+ 5.30
		Wires 12 inches from centre	+ 3.17
		Wires 14 inches from centre	- 0.17
		Wires 16 inches from centre	- 5.45

The following experiment is on the middle 3 feet of Mr. BAILY'S tubular 5-foot scale, No. 5. The lines on the upper surface. [It would seem that it took a faulty bearing when laid flat on the bar.] Single readings.

1843. Sept. 17.	Bar lying flat	div. + 37·8
	Pins at 13½ inches and 46½ inches...	+ 28·0
	Rollers at 14½ inches and 45½ inches	+ 32·0
	Pins at 15½ inches and 44½ inches...	+ 32·5
	Pins at 16½ inches and 43½ inches...	+ 36·0
	Pins at 17½ inches and 42½ inches...	+ 35·5
	Pins at 18½ inches and 41½ inches...	+ 38·5
	Bar lying flat	+ 38·0

The bar of gun-metal No. 3 was then reduced to the length 37 inches, and lines were cut (evidently on its upper surface) at the distance 36 inches, and five experiments were made on 1843, Sept. 28 and 29. The following is the mean of results:—

	div
Bar lying flat	+ 2·41
Wires under the centre	+ 5·85
Wires 2 inches from the centre ...	+ 9·51
Wires 4 inches from the centre ...	+ 9·19
Wires 6 inches from the centre ...	+ 7·39
Wires 8 inches from the centre ...	+ 4·49
Wires 10 inches from the centre ...	+ 1·19
Wires 12 inches from the centre ...	− 0·75
Wires 14 inches from the centre ...	− 4·11
Wires 16 inches from the centre ...	− 8·69
Wires 18 inches from the centre ...	− 11·61

The same bar was then supported on rollers at different intervals, and eight experiments were made on 1843, October 10 and 11; of which the following are the means:—

	div.
Rollers 0·75 inch on each side of centre.....	0·00
Rollers 4 inches on each side of centre	+ 0·06
Rollers 6 inches on each side of centre	− 2·71
Rollers 8 inches on each side of centre	− 4·99
Rollers 10 inches on each side of centre	− 7·45
Rollers 12 inches on each side of centre	− 9·81
Rollers 14 inches on each side of centre	− 12·93
Rollers 16 inches on each side of centre	− 16·03
Rollers 18 inches on each side of centre	− 21·34

On 1843, October 16, I supplied Mr. BAILY with the formulæ defining the intervals at which rollers ought to be placed beneath a bar in order that the flexure of the bar might not influence the measure of the distance between two lines upon the upper surface (the rollers being supposed to exert equal pressures upwards). With two rollers, the interval ought to be $\frac{\text{length of bar}}{\sqrt{3}}$; with four rollers, each interval = $\frac{\text{length of bar}}{\sqrt{15}}$; with eight rollers, each interval = $\frac{\text{length of bar}}{\sqrt{63}}$ *. Lever-frames were afterwards prepared, each with eight rollers.

It has been remarked above, that Captain KATER had constructed for the Royal Society a standard on the principle proposed by himself, of carrying a slender scale in a groove cut in a stout bar; as it appeared probable that the effect of a given degree of

* See Mem. Astron. Soc. vol. xv.

flexure in altering a measure cut upon the upper surface would be much less for a thin scale than for a thick one. In order to test this, Mr. BAILY caused two slight marks to be cut upon the stout bar of the Royal Society's scale, and made five experiments on 1843, December 24, of which the following numbers are the means. The wires used were common large pins.

Measures of intervals upon the slender scale	}	Bar laid flat	div.	0·0
		Wire under the middle	+	0·1
		Wires under the ends	-	6·0
Measures of intervals upon the surface of the stout bar	}	Bar laid flat		0·0
		Wire under the middle	+	5·2
		Wires under the ends	-	42·0

In order to collect together the observations which may be considered as applying to the reduction of comparisons of standards, before entering upon the comparisons themselves, I shall interrupt the chronological order (as I have already done) to give the results of experiments on thermometric expansion made by Mr. SIMMS, at 138 Fleet Street, under the general instruction of Mr. BAILY, with some suggestions by myself.

A tin trough was prepared, 44 inches long, 5 inches wide, and 5 inches deep, supported on four screws. Glass windows were provided in proper places for admitting lateral illumination. A lever-frame with eight rollers (on the principles to which I have already adverted) was placed in the trough, and the bar which was the subject of experiment was placed upon the rollers. The trough was filled with water, of any required temperature, which could be heated by spirit-lamps below the trough. The microscopes were fixed to a stone ledge built into the wall of the room. The object-glasses of the microscopes (which were common object-glasses of unusually short focal length) were immersed in the water. At all ordinary temperatures the vision was quite distinct, even with the trough uncovered: when the temperature was high, the vision was indistinct, except the trough was covered, but was very good when it was covered. The thermometers were placed in the water, on the surface of the bar. I imagine that these experiments may challenge comparison with any that ever were made, in every respect except one, viz. that the thermometers employed, though probably as good as any then in existence, did not possess the authority which was acquired by thermometers subsequently made by independent graduation.

A screw-apparatus was provided, acting in opposition to a spring, by which the line at one end of the bar could be brought under the microscope at that end; and the micrometer-movement of that microscope was never used. The value of one division of the micrometer which was employed was ascertained to be 0·000025287 inch. The bars which were the subject of examination were evidently not the same as those already mentioned; for the gun-metal bars are all described at this time (1844, February) as being 40 inches long; whereas, of the formerly-mentioned bars, No. 4 had been broken and No. 3 had been shortened before the end of 1843.

On my application to the Lords Commissioners of the Treasury, the ruined Imperial Standard was in March 1844 placed in the hands of Mr. BAILY; and the experiments on its expansion are here detailed after the others.

It will be remarked that some comparisons are made with the temperature rising and some with the temperature falling. There appears to be no sensible difference in the results.

Description and length of bar.	Thermometer-reading.		Change of length.	Modulus for 1° FAHR.	Modulus deduced from the compound expansion.
	First.	Second.			
Gun-metal (?) No. 1, 40 inches.	46·90	98·25	div.	·0000095970	} ·0000094859
	47·20	94·37	780·00	95959	
	33·70	94·65	716·00	96823	
	94·65	67·05	933·50	100209	
	67·05	46·50	437·50	87674	
Gun-metal No. 2, 40 inches.	46·90	97·15	771·50	·0000097059	
	97·15	42·25	881·00	101447	
	41·55	95·55	799·70	93621	
Gun-metal No. 3, 40 inches.	38·35	98·30	935·30	·0000098627	
	96·95	45·35	817·60	100168	
	32·00	97·85	1005·00	96482	
Gun-metal No. 4, 40 inches.	33·65	99·05	994·03	·0000096086	
	99·05	42·95	818·23	92204	
Brass tube, 40 inches.	32·70	98·52	1047·75	·0000100632	} ·0000102345
	98·52	170·25	1179·10	103932	
	170·25	32·65	2253·85	103548	} 102433
	35·15	98·67	1020·50	101564	
	98·67	171·50	1188·83	103206	} 103745
	171·50	118·10	858·83	102170	
	118·10	40·95	1283·60	105174	} 105092
	34·35	106·35	1181·50	103738	
	106·35	183·75	1302·10	106351	} 105554
	183·75	99·02	1442·95	107661	
	99·02	37·20	1004·00	102699	} 105892
	33·65	97·23	1033·67	102778	
	97·23	176·17	1353·60	108405	
	176·17	100·45	1295·17	108132	
Brass bar, 40 inches.	40·60	98·91	890·55	·0000096550	} ·0000101079
	98·91	45·35	828·75	97818	
	45·00	99·72	858·26	99154	
	99·72	177·95	1267·49	102425	
	177·95	98·35	1307·65	103852	
	98·35	37·45	940·50	97629	
	35·05	100·17	1004·40	97491	
	100·17	176·92	1246·72	102690	
	176·92	88·75	1446·27	103697	
	88·75	35·80	805·90	96217	
Steel bar, 40 inches.	37·25	97·13	559·47	·0000059056	} ·0000062284
	97·13	43·75	520·07	61592	
	33·25	89·22	516·35	58321	
	89·22	176·10	891·05	64836	
	176·10	100·58	787·24	65900	
	100·58	34·67	620·73	59537	

TABLE (continued).

Description and length of bar.	Thermometer-reading.		Change of length.	Modulus for 1° FAHR.	Modulus deduced from the compound expansion.
	First.	Second.			
Copper bar, 40 inches.	37 ^o 25	98 ^o 60	div. 865 ^o 30	•0000089164	•0000094103
	98 ^o 60	177 ^o 95	1229 ^o 10	97921	
	177 ^o 95	100 ^o 42	1231 ^o 50	100418	95993
	100 ^o 42	38 ^o 10	892 ^o 05	90489	
	40 ^o 65	94 ^o 05	782 ^o 56	92643	94914
	94 ^o 05	170 ^o 70	1169 ^o 96	96493	
	170 ^o 70	99 ^o 66	1103 ^o 22	98174	94750
	99 ^o 66	43 ^o 27	806 ^o 70	90437	
	112 ^o 40	183 ^o 45	1084 ^o 72	96514	95547
	183 ^o 45	99 ^o 63	1302 ^o 92	98267	
	99 ^o 63	51 ^o 50	691 ^o 38	90811	
Old Imperial Standard, 36 inches.	47 ^o 35	99 ^o 50	752 ^o 50	•0000101356	•0000104456
	99 ^o 50	176 ^o 27	1164 ^o 67	106318	
	176 ^o 27	99 ^o 20	1187 ^o 92	108267	104469
	99 ^o 20	48 ^o 70	710 ^o 40	98811	
	50 ^o 80	38 ^o 80	165 ^o 65	96963	102843
	38 ^o 80	99 ^o 27	847 ^o 75	98474	
	99 ^o 27	178 ^o 45	1196 ^o 92	106180	104648
	178 ^o 45	99 ^o 87	1205 ^o 72	107778	
	99 ^o 87	50 ^o 45	703 ^o 70	100018	103205
	50 ^o 45	41 ^o 50	130 ^o 90	102733	
	52 ^o 85	39 ^o 90	180 ^o 45	97877	103734
	39 ^o 90	97 ^o 85	800 ^o 70	97053	
	97 ^o 85	168 ^o 70	1091 ^o 75	108163	103734
	168 ^o 70	99 ^o 72	1057 ^o 59	107693	
	99 ^o 72	54 ^o 15	651 ^o 06	100552	
54 ^o 15	37 ^o 50	228 ^o 94	96583		
Glass bar, 36 inches.	53 ^o 90	96 ^o 60	300 ^o 95	•00000495	•0000051525
	96 ^o 60	174 ^o 60	584 ^o 42	526	
	174 ^o 60	97 ^o 86	583 ^o 22	534	51157
	97 ^o 86	49 ^o 65	326 ^o 80	476	
	50 ^o 00	38 ^o 43	80 ^o 92	492	50591
	38 ^o 43	99 ^o 35	412 ^o 80	476	
	99 ^o 35	176 ^o 02	578 ^o 19	530	51157
	176 ^o 02	99 ^o 16	583 ^o 02	533	
	99 ^o 16	43 ^o 47	382 ^o 35	482	50404
	51 ^o 45	99 ^o 20	340 ^o 33	501	
	99 ^o 20	174 ^o 92	545 ^o 67	506	51339
	174 ^o 92	98 ^o 70	564 ^o 93	522	
	55 ^o 50	38 ^o 28	116 ^o 34	473	51938
	38 ^o 28	98 ^o 75	416 ^o 67	484	
	98 ^o 75	168 ^o 93	538 ^o 23	539	51938
	168 ^o 93	98 ^o 67	529 ^o 46	529	
98 ^o 67	57 ^o 00	303 ^o 20	511		
57 ^o 00	41 ^o 43	110 ^o 10	497		

It will be remarked that the modulus of expansion, in every instance, is greater for the high temperatures than for the low ones. As the same thermometers were used throughout, it is possible that this may arise from an error in the graduation of the thermometers; but it is not improbable that it is a real peculiarity in the relation between the expansion of the solid metals and that of quicksilver. Admitting the truth

of the apparent difference, it becomes necessary to define the temperature near which any numerical value of the modulus is supposed to apply. Mr. SHEEPHANKS, after discussing these experiments, fixed upon the following as representing the linear expansion for 1° of FAHRENHEIT at temperatures differing little from 62° FAHRENHEIT, the length of the bar being 36 inches:—

	inch.
Metal No. 1 (Brass)	0·000343
Gun-metal No. 2	0·000351
Gun-metal No. 3	0·000354
Gun-metal No. 4	0·000339
Brass Tube	0·000367
Brass Bar	0·000350
Copper	0·000326
Steel	0·000212
Glass	0·000178
Brass of the Imperial Standard .	0·000355

I now proceed with the Comparisons of Standards, made by Mr. BAILY at his house, 37, Tavistock Place, with the purpose of ascertaining the state of the materials available for the restoration of the length of the lost Imperial Standard.

Besides the SHUCKBURGH Scale (to which, on account of its imperfections and the doubts and discordances in its comparisons, little importance was attached), it was known that five existing standards, of superior construction, had been compared with the Imperial Standard; namely, the Royal Society's 3-foot brass scale (constructed by Captain KATER), the Royal Astronomical Society's brass tubular scale, two iron bars belonging to the Ordnance Department and preserved in the office of the Trigonometrical Survey, and a 3-foot brass scale (constructed by Captain KATER and similar to that of the Royal Society), in the possession of a private person. The loan of the last-mentioned standard was refused to the Commission; but I had obtained the four first-mentioned from their owners and custodiers, and delivered them on 1843, December 5, to Mr. BAILY.

After some preliminary observations, Mr. BAILY made the following comparisons:—

The Royal Society's scale compared with the middle 3 feet of the Royal Astronomical Society's scale. The Royal Astronomical Society's scale supported on its rollers, at quarter-length distance from the centre. The Royal Society's scale lying flat on the T-bar of the frame, and nearest to the observer. There appears to have been no difficulty in the observation, except from the size of the dots on the Royal Society scale, the breadth of each being 77 divisions of the micrometer. The Royal Astronomical Society scale is longer than the Royal Society's scale,—

	°	inch.
1844, Jan. 2, from 20 comparisons at temperature	43·21 FAHR.,	by 0·000564
3, from 20 comparisons at temperature	38·20 FAHR.,	by 438
4, from 20 comparisons at temperature	40·90 FAHR.,	by 699
5, from 20 comparisons at temperature	46·34 FAHR.,	by 664
6, from 20 comparisons at temperature	50·20 FAHR.,	by 637
Mean by 100 observations . . .		0·000600

The Ordnance Bar 1A compared with the middle 3 feet of the Royal Astronomical Society's scale. It appears that the Bar 1A was put in the place of the Royal Society's scale. The bar is notched at each end to half its depth, and the defining points are upon gold pins in the surfaces thus exposed. In the first and second series, the iron bar was laid on two semicircular brass pieces 18 inches apart (not on rollers), in the same manner as when the bar was compared with the Imperial Standard *. In the third, fourth and fifth, it was placed on rollers. A doubt on the temperature exists, for the following reason. After the comparisons had been made, Colonel COLBY informed Mr. BAILY that the thermometer of 1A gave indications too low by 1°. Mr. BAILY however states that in the first five comparisons the thermometer of 2A was used. Yet the simultaneous readings of thermometers seem to make it probable (but not certain) that the thermometer of 1A was really employed. If so, the mean temperature in the following Table ought to be increased 0°·5. The Ordnance Bar 1A is longer than the Royal Astronomical Society's scale,—

	°	inch.
1844, Jan. 7, from 20 comparisons at temperature	47·32,	by 0·001300
8, from 20 comparisons at temperature	43·82,	by 1754
9, from 20 comparisons at temperature	42·62,	by 1999
10, from 20 comparisons at temperature	41·85,	by 2067
11, from 20 comparisons at temperature	43·10,	by 1872

The Ordnance Bar 2A compared with the middle 3 feet of the Royal Astronomical Society's scale. In the first two series, the bar was supported on its semicircular brass pieces; in the others, on rollers. The thermometer of 2A was undoubtedly employed. The Ordnance Bar 2A is longer than the Royal Astronomical Society's scale,—

	°	inch.
1844, Jan. 12, from 20 comparisons at temperature	43·72,	by 0·002108
13, from 20 comparisons at temperature	44·60,	by 2035
14, from 20 comparisons at temperature	43·52,	by 2148
15, from 20 comparisons at temperature	40·72,	by 2519
16, from 20 comparisons at temperature	36·97,	by 2958

* Royal Astronomical Society's Memoirs, vol. ix., and Measure of the Base on Lough Foyle.

The Ordnance Bar 1A was now put in the place of the Royal Astronomical Society's scale, and 1A and 2A were both supported on rollers. 2A is longer than 1A,—

1844, Jan. 17, from 20 comparisons at temperature 38°25,	by	0·000423	inch.
18, from 20 comparisons at temperature 41·65,	by	367	
20, from 20 comparisons at temperature 42·55,	by	311	
22, from 20 comparisons at temperature 44·10,	by	359	
23, from 20 comparisons at temperature 43·12,	by	313	

Three bars (the Royal Astronomical Society's scale, 1A and 2A) were now mounted together; the Royal Astronomical Society's scale being furthest from the observer, and 2A nearest to him. 1A and 2A were supported each on its own semicircular pieces, which were carried by the same supporting bar. The Ordnance Bar 1A is longer than the Royal Astronomical Society's scale,—

1844, March 13, from 10 comparisons at temperature 42°67,	by	0·002203	inch.
14, from 10 comparisons at temperature 42·13,	by	2520	
15, from 10 comparisons at temperature 43·82,	by	2140	

And Ordnance Bar 2A is longer than the Royal Astronomical Society's scale,—

1844, March 13, from 10 comparisons at temperature 42°67,	by	0·001875	inch.
14, from 10 comparisons at temperature 42·13,	by	2055	
15, from 10 comparisons at temperature 43·82,	by	1751	

Here 1A appears longer than 2A; whereas the previous observations had made 2A longer than 1A. The only circumstance with which this discordance could be connected was this: that when (as in this instance) the two iron bars were supported by brass semicircular pieces resting upon the same T-bar, it was necessary to place cards under the brass semicircles of 1A, in order to bring them to the same height.

The Ordnance Bars 1A and 2A were now mounted, each on its own semicircular pieces, and on separate T-bars. The Bar 2A is longer than 1A,—

1844, March 16, from 20 comparisons at temperature 46°25, by 0·000211 inch.

The arrangement was then altered, merely by placing cards under the semicircular pieces of 1A and depressing its T-bar properly. The Bar 1A is then longer than 2A,—

1844, March 18, from 10 comparisons at temperature 44°0, by 0·000054 inch.

Then the semicircular pieces (those of 1A having cards beneath them) were placed on the same T-bar. The Bar 2A is longer than 1A,—

1844, March 19, from 10 comparisons at temperature 45°0, by 0·000318 inch.

I shall depart from chronological order, for the purpose of inserting two series of

observations connected with the same subject, but at a higher temperature in a very steady season.

The Royal Astronomical Society's Standard and Ordnance Bar 1A were mounted as formerly (1A upon its semicircular pieces), and the Royal Astronomical Society's Standard was longer than 1A,—

1844, May 14, from 20 comparisons at temperature $65^{\circ}5$, by 0.001185 inch.

Then 2A was inserted in place of 1A, and after waiting some time for steady weather, the following comparison was made, giving the Royal Astronomical Society's Standard longer than 2A,—

1844, June 17, from 20 comparisons at temperature $65^{\circ}47$, by 0.001222 inch.

This is the last comparison made by Mr. BAILY.

In the month of April Mr. BAILY was occupied with comparisons intended to verify the invariability or variability of the Royal Astronomical Society's Standard. They consisted, partly of comparisons of the middle 3 feet of that scale with the middle 3 feet on other tubular scales, of exactly similar construction, with which it had been compared in the year 1835; and partly of comparisons of different measures on the same tube, which also had been compared in 1835.

The Royal Astronomical Society's scale was found to be shorter than Mr. BAILY's tubular scale No. 5,—

1844, April 8, from 20 comparisons at temperature $50^{\circ}67$, by 0.000120 ^{inch.}
 9, from 20 comparisons at temperature 52.61 , by 161

In 1835, the Royal Astronomical Society's scale was longer than Mr. BAILY's by 0.000046 inch.

Mr. SIMMS's tubular scale No. 4, of construction exactly similar, was substituted for Mr. BAILY's. The Royal Astronomical Society's scale was found to be shorter than Mr. SIMMS's No. 4,—

1844, April 14, from 20 comparisons at temperature $56^{\circ}33$, by 0.000180 ^{inch.}
 15, from 20 comparisons at temperature 56.90 , by 163

In 1835, the Royal Astronomical Society's scale was longer than Mr. SIMMS's by 0.000102 inch.

Mr. BAILY's scale No. 5 and Mr. SIMMS's No. 4 were then mounted together, each on its own rollers; and Mr. BAILY's was found to be shorter than Mr. SIMMS's,—

1844, April 16, from 20 comparisons at temperature $57^{\circ}11$, by 0.000087 ^{inch.}
 17, from 20 comparisons at temperature 56.76 , by 116

In 1835, Mr. BAILY's was longer than Mr. SIMMS's by 0.000042 inch.

Mr. BAILY then made the following comparisons of measures defined by lines cut on different parts of the Royal Astronomical Society's Tube. Near to the two extremities of the 5-foot tube, transversal lines had been cut (known by the letters A, *a*) crossing the continuation of the line of the divided scale; then, supposing the tube to be turned round its axis through 90°, two similar transversal lines B, *b*, were cut; turning the tube 90° further, two similar lines C, *c*, were cut, which therefore were on the side of the tube opposite to A, *a*; turning the tube 90° further, two similar lines D, *d*, were cut. The comparison of the longitudinal intervals between these was the object of the following observations:—

1844, April 21, at temperature 60°, by six comparisons in each case, the excesses of the various measures above *Aa* were as follows:—

	inch.
<i>Bb</i> exceeds <i>Aa</i> by	−0·000009
<i>Cc</i> exceeds <i>Aa</i> by	+0·000126
<i>Dd</i> exceeds <i>Aa</i> by	−0·000015

In 1835 the corresponding differences were

−0·000056
+0·000056
−0·000169

This was the last special inquiry on which Mr. BAILY was engaged.

Mr. BAILY died on 1844, August 30.

The state of the problem at this time, as regarded the restoration of the Standard, was nearly as follows. The object might be considered: either to reproduce in a satisfactory form the value of the Scientific Standard (SHUCKBURGH'S), which Captain KATER considered as a scientific representative of the National Standard of Length; or to reproduce the Legal Standard. With regard to SHUCKBURGH'S scale: the experiments of Mr. BAILY had confirmed the remarks which originated with Captain KATER himself, that minute circumstances, whose effect was totally unsuspected in the earlier comparisons of this scale, produced a disturbance in the apparent length, which might have deranged in different directions the results of its comparisons for physical measures, and whose magnitude was intolerably great; that there was no security whatever that, in retaining documentary or numerical expressions of measure founded on this scale, we were referring to a consistent system; and that in future it would be better to lay aside this scale entirely. With regard to the Legal Standard: the principal difficulty, inherent in the standard itself, arose from the size and irregular form of its defining dots, which indeed made accurate comparison impossible. With regard to the existing scales which had been compared with the Legal Standard: the Tubular Scale of the Royal Astronomical Society (complicated in its mechanical structure) was found to have changed, in itself, and by comparison with similar scales, in a way and to an amount which ruined its credit; the Ordnance Bars (of firm and simple structure) appeared in themselves trust-

worthy, but the injurious effects of their supports, and an uncertainty in the temperature referred to one thermometer, introduced great irregularities in their comparisons and doubts in the reductions of them. The Royal Society's Scale had been carefully constructed in reference to one apprehended cause of error; but it seemed likely that a construction so complicated might introduce other errors of equal magnitude; and it appeared certain that the form already partially introduced (a stiff bar supported at many points by free roller-motion) would be far less liable to error. Finally, there ran through the whole of these comparisons one specific cause of uncertainty: nobody knew the authority for any one of the thermometers used, no one doubted that they might be very sensibly in error, and two thermometers inclosed in the same box and intended to be used with the two Ordnance Bars actually differed an entire degree.

It was plain therefore that, either in the scientific or in the legal sense, the restoration of the Standard was indeterminate. The formation of a New Standard must be an operation *de novo*; the length must be confined within certain limits (wide in the scientific, narrow in the commercial sense), but within these it might have any definite value; and when that definite value was fixed, it must in no way be again referred to the old standards or scales, whether original or intermediary. The principal object now was, to ensure constancy and definiteness to the new Standard and its copies, and means of reducing without sensible error the comparisons which might be made with them. As far as depended on the Standard itself, it was hoped that the construction adopted gave sufficient security. As regarded the means of making comparisons, a far firmer apparatus than had hitherto been used was requisite. As regarded the effects of temperature, it was necessary to create an entirely new system of thermometers, founded upon the natural constants, to be determined by appropriate physical experiments; and to use them in new determinations of thermometric expansion.

Such is the state in which the problem was left to Mr. BAILY'S successor.

SECTION IV.—*Proceedings of the Committee and of Mr. SHEEPSHANKS to 1847, June; construction of new Thermometers, and erection of Comparing Apparatus; description of the Apparatus, and of Mr. SHEEPSHANKS' method of comparing.*

The Committee at their meeting of 1844, November 30, received with pleasure and thankfully accepted Mr. SHEEPSHANKS' offer to continue the work commenced by Mr. BAILY. Intimation of this arrangement being given to the Lords Commissioners of the Treasury, a request to the same effect was addressed by their Lordships to Mr. SHEEPSHANKS and assented to by Mr. SHEEPSHANKS; Mr. SHEEPSHANKS, like Mr. BAILY, declining to accept pecuniary remuneration. I had received from Mr. BAILY'S representatives the four bars on which the restoration of the standard was to be founded, as also the MS. books of comparisons, and I placed them in Mr. SHEEPSHANKS' hands.

At the Meeting of 1845, June 6, Mr. SHEEPSHANKS communicated a Report to the following effect:—

“The object proposed appears to be the restoration of the length of the lost Parlia-

mentary Standard representing the Imperial Standard Yard. The composition of this bar is not known. The defining points were large and irregular dots (upon gold pins, melted out by the fire of the Houses of Parliament), which did not admit of accurate observation. This bar, and other bars compared with it (Sir GEORGE SHUCKBURGH'S, the Royal Society's, and Colonel COLBY'S), were usually laid for comparisons (it is believed) on a flat surface, in which arrangement, as is now known, the metal is in constraint, and the comparisons are liable to considerable error. On the completion of the Royal Astronomical Society's scale, it, as well as other scales of similar construction, were compared with the Parliamentary Standard: though these comparisons were more accurately made than those already cited, yet the mounting of these scales is liable to some objection, and sufficient attention was not given to their thermometric expansions at the temperatures in which they were commonly used. A more serious difficulty is this: when, for the scales of the construction similar to that of the Royal Astronomical Society, the same method of supporting is used as was used in their first comparisons, the difference between the lengths of the different scales is not found to be the same as it was at those first comparisons; the discordance being $\frac{1}{5000}$ th of an inch, or perhaps twice the probable error of one micrometer-reading. Moreover, the intervals between divisions engraved on four sides of the Royal Astronomical Society's scale do not preserve the same relation as formerly, the discordance being about $\frac{1}{10,000}$ th of an inch. The difference between the lengths of Colonel COLBY'S bars appears to be sensibly the same as it was formerly; but there are other objections to the accuracy of comparisons derived from these bars: they are of different metal from the Standards; their expansions have not been ascertained; their thermometers do not correspond; they were not properly supported. It is (in Mr. SHEEPHANKS' opinion) an advantage that they are made of a pure metal. References to the determinations of the length of the pendulum may be rejected at once, not only because they are inaccurate, but also because they are in fact expressed in terms of SHUCKBURGH'S scale, and not in terms of the Parliamentary Standard. Mr. SHEEPHANKS considers therefore that our materials for restoration are generally unsound; and that with our endeavours to give the best evidence in our power as to the past, we must combine, what is now more important, the discussion of methods for avoiding similar difficulties for the future. For this purpose it appears necessary to investigate anew the questions of stability and thermometric expansion of standards, and to devise better methods of comparing standards than have hitherto been used. And in the pursuit of these inquiries Mr. SHEEPHANKS proposes to reject all considerations but those of accuracy and permanence; to adopt the most complete and convenient mode of experimenting, regardless of time, trouble in preparation, and (to a certain degree) of expense. Mr. SHEEPHANKS then gave the following sketch of his proposed plan of operations:—

“The place of experiments to be in the lower cellars of Somerset House, in the apartments of the Royal Astronomical Society.

“The supports of the microscopes to be built of large squared stones.

“ The bars when under examination to be placed in a drop-box surrounded by a large mass of water.

“ For ascertaining actual thermometric expansion, the drop-box of one bar is to be placed in ice, and that of the expanding bar in water of different temperatures, and these are to be compared repeatedly by the microscopes. [This arrangement was not precisely carried out.] A similar method will be used for ascertaining whether after repeatedly heating and cooling one bar, it returns to the same length. [This was not specially done.]

“ Bars of iron, copper, and cast steel, have been prepared, in addition to the bars of gun-metal prepared under Mr. BAILY'S direction. Mr. SHEEPSHANKS proposes to compare carefully bars of these metals and alloys, and also to determine their minimum time of vibration, and after some time to repeat these observations. The object of this is to ascertain the permanency of the bars. For the vibration observations, apparatus for swinging *in vacuo* is now in preparation. [This was not effected.] All these operations ought to precede the comparisons for restoration of the lost standard.

“ Mr. SHEEPSHANKS then remarked that (for reasons already given) it appears impossible to restore the standard with reasonable accuracy, and he suggested therefore for consideration whether it might not be better to adopt the length which has been used in the measurement of Colonel COLBY'S base for the Trigonometrical Survey of Ireland. This appears permissible, because there is sufficient latitude in the vagueness of comparison of the old standard to allow it; and it appears worthy of recommendation, because (as Mr. SHEEPSHANKS understands from Colonel COLBY) the length adopted in the Irish base appears to correspond very exactly with the length adopted in General ROY'S base on Hounslow Heath. Logically there is no inconsistency in this course, because the divisions of the 10-foot iron bars used by Colonel COLBY were laid down from TROUGHTON'S scale, from which also the divisions of Sir GEORGE SHUCKBURGH'S scale (judged by Captain KATER to be equivalent to the old Parliamentary Standard) were laid down. Mr. SHEEPSHANKS proposed therefore to make a 3-foot iron bar, to compare it with the scales which were directly compared with the old Parliamentary Bar (for general information), and to multiply it by $\frac{10}{3}$, and then to compare it with Colonel COLBY'S 10-foot bars; and from this latter comparison to infer the length proper for the new National Standard.

“ A subsequent process, but still distant, would be the preparation for comparisons with measures *à bouts* and for pendulum experiments.”

The following are further extracts from the Minutes of the same meeting (1845, June 6):—

“ Mr. AIRY stated, in reference to the question of the use of alloys or pure metal, that he had just heard that great difficulty had been experienced by Messrs. MAUDSLAYS in casting a bar of pure copper; the cast being honey-combed and full of bubbles.

“ On consideration of Mr. SHEEPSHANKS' report, it was Resolved,—

“That the thanks of the Committee are due to Mr. SHEEPSHANKS for the spirit with which he has entered into the investigation of all the difficulties connected with the formation and perpetuation of a standard of length.

“That the Committee approve most fully of the steps taken by Mr. SHEEPSHANKS in the preparation of new apparatus (as described by him), for the examination of all the causes of error, for the investigation of the thermometric correction, for the ascertaining the permanency of standard bars, and for the accurate comparison of bars.

“The question of adoption of the measures derived from the Survey was deferred.”

Mr. SHEEPSHANKS now turned his attention energetically to the practical preparation of the various apparatus to which his Report alludes. Of the details of the incessant labour of the next two years, few traces remain except in Mr. SHEEPSHANKS' correspondence with myself. But to these labours there was little interruption. Old apparatus was to be tested and new to be planned and carried into execution; instrument-makers much occupied with other business were to be kept closely to the work; manipulations of various kinds were to be learnt; and all was done under the disadvantage of Mr. SHEEPSHANKS' domestic residence being at Reading, while the work of every kind was executed in London. The most tedious of the operations actually carried on appears to have been the preparation of original thermometers (or rather the acquisition of the experience necessary for their preparation, for I do not think that a thermometer was really finished before the end of 1847). It would seem that at this time there was no workman in London who could be trusted, without the closest superintendence even in the minutest points, to make a thermometer. At length Mr. SHEEPSHANKS found himself so far prepared that he deemed it necessary to apply to the Committee for further instructions. The following are extracts from the Minutes of the Meeting of 1847, June 4:—

“Mr. SHEEPSHANKS made a statement to the following effect:—

“The tardiness in the proceedings connected with the Standard of Length has arisen from the delays incidental to the planning of new machinery, and of having it executed when all the workmen are busy.

“I conceive the ultimate object to be, to procure a permanent standard, which can be easily multiplied and widely distributed, which is to be connected with our best existing measures, with the base of the Trigonometrical Survey, and with the standard measures of other countries.

“But the immediate want is for an actual type of the standard measure. Therefore, although it will be desirable (in the scientific order) to end with establishing the standard, I believe it will be best for public convenience to begin with it.

“The first considerations which occupied my attention were the *permanency* of bars and the mode of perpetuating any measure. I propose to ascertain whether and how much a bar has altered in the following manner. Bars of different metals, of the same dimensions as those proposed for the standards, are to have each a yard marked on it,

and are besides to be converted into pendulums, each oscillating on a knife-edge placed where it makes the time of vibration a minimum. If the period of vibration of the same bar at the same place is unchanged by time, gravity being supposed unchanged, then the whole length of the bar is unchanged; and the distance of the divisions marked on it, supposing the bar to continue straight, is unchanged. The bar must of course be guaranteed from rust or change of shape. As the test of actual length is required to be very exact, the series of experiments should be continued without interruption as long as possible. I have therefore had an apparatus constructed for swinging these pendulums *in vacuo*, which, so far as I can judge, will give almost any degree of accuracy to this part of the inquiry, with very little trouble to the observer; this was in fact my first step, and until this was secured I did not think it worth while to apply myself to the rest of the apparatus.

“The next point is, the very accurate comparison of two bars with each other, the bars being supposed of the same material. Connected with this is, the determination of the law of expansion of the metal that may be used, at usual and moderate temperatures. The preparations for this apparently simple operation will perhaps appear complicated. I should however be unwilling to give up any of them; so important do I hold this solidity of the apparatus to be.

“The real difficulties in the practical problem have been, so far as I can judge, the instability of the optical beam compass employed, the unsatisfactory mode of supporting the bar, the want of due verification of the axes of the microscopes, and the variations of temperature, which were not indicated by the measuring means employed. Thus, in Mr. BAILY'S apparatus [the apparatus of the Royal Astronomical Society], which was certainly an improvement on all that preceded it, the observer's body had a sensible effect on the bar which carried the microscopes, and probably on the direction of their axes; it also affects differently the temperature of the two bars and that of the thermometers. These effects may be partly eliminated by interchanging the bars, &c.; but there is another cause of error which cannot be eliminated, namely, that the beam which carries the microscopes is affected by the motion of the frame which carries the bars. [Mr. SHEEPHANKS then described an experiment of the comparisons of three iron bars, in which every single reading of the microscopes was very satisfactory, yet the result as relating to the difference of length of the three bars was unsatisfactory.]

“Having thus arrived at the conviction of the absolute necessity of a steady stand and an immoveable beam compass, I have tried to obtain them in the manner which you will see.

“The principle I have had constantly in my mind has been this. We do not know where the difficulties may be: let us not throw away a chance; let us take care to provide for all known contingences, regardless of cost, and trust to combating the unknown difficulties when they are found. It seemed to me not suitable to the Committee, nor indeed to our national character, to try any but the best conceivable means, and I have acted for the Government as I would do for myself.

“I will now say a few words on the question of measuring temperature, leaving the measurement of the expansion of the bars aside.

“A little consideration showed me that there was no use in making most accurate comparisons, unless I had most accurate means of measuring the temperature also; and that I required to know the reading of the thermometer to at least the $\frac{1}{20}$ th of a degree of FAHRENHEIT. I soon found that there was no reasonable expectation of procuring such thermometers, and I proceeded as follows:—

“Mr. SIMMS assigned me a very intelligent and zealous workman, who, after some disappointment of external aid, undertook to graduate the thermometers himself. The tubes were divided by the dividing engine (probably as well as it could be done) to 180 equal parts, from somewhere below freezing to about boiling. He then bit-in the divisions by fluoric acid.

“The thermometer with the tube thus prepared comes into my hands. By a column of mercury occupying about 90 parts, the whole length is bisected and the error of the 90 divisions ascertained, and also the error of 30 relative to 120, and that of 150 relative to 60. Next with a column of mercury occupying about 60 parts, which is carried in three steps from 0 to 180, the errors of 60 and 120 are found, and thus (as above) those of 30 and 150 are known. Also by carrying the column of 60 parts backwards and forwards from 90, new measures of the errors of 30 and 150 are obtained; if these agree with the former, the errors of 30 and 150 are well known. Then with a column of about 50 parts, which is carried in three steps from 0 to 150 and from 30 to 180, the divisions 50, 100, 80, 130 are corrected; and the length of this 50 column being now well known, it is used by application to the former divisions to subdivide to every 10. A column of 45 parts will then subdivide all to every 5, and this subdivision is checked by the comparison of each 5 with the mean of the adjacent 10. I have learned the manipulation of a thermometer so as to break the column myself, and have thus saved much trouble. [Mr. SHEEPHANKS then described the practical method of performing this operation.]

“The next thing is to settle the boiling- and freezing-points (as all the determinations already described are referred to degrees 0 and 180, which may be erroneous). There is no difficulty as to the freezing-point; a great number of observations showed me that with proper precautions I could rely on it to about $\frac{1}{100}$ th of a degree. The boiling-point presented some difficulty, until the following method was adopted. The water is boiled in a close vessel having apertures for the escape of steam under control, and these are regulated till there is just no sensible pressure on a mercurial siphon communicating with the interior. [The bulb, as I understand, was surrounded by steam.] The thermometer may now be considered as completely made.

“But there is an anomaly which offers some difficulty. Take an old thermometer, ascertain its freezing-point, boil the thermometer, ascertain its freezing-point again, and you will find it has fallen from one-third to one-fourth of a degree. I found a sensible though not a large change by raising the temperature to 100°. I believe

that the freezing-point rises in time to its old place, to be again displaced by a fresh boiling.

“This difficulty I propose to meet thus. I take properly graduated thermometers which are of some age, and of which the freezing-points are carefully ascertained. I compare these with standard thermometers which have just been verified, at temperatures as high as I can get by natural means (say as high as 70° or 80°). Then those (*i. e.* the old thermometers) are good so long as the freezing-point does not alter; and I expect that it will not alter, for these thermometers will not be exposed to severe changes of temperature. If it should alter, the correction of the freezing-point will be common to all the readings. I intend to make these comparisons by putting the standard and other thermometers into the iron trough, and reading with the telescope.

“The experiments for expansion will be made for those temperatures which naturally occur for such experiments, and not much higher.

“What I have now to ask is, that you approve or disapprove of what I have done, and sanction the payment of the expense incurred, except so much as refers to the thermometers. This is not very large, and is as yet incomplete; nor can it be said whether some portions of the apparatus may not belong rather to the artist than to Her Majesty's Government.

“I now come to the point on which I particularly require direction.

“I intend to inquire into and to leave means for inquiring into the best material for a standard bar. But this will be a work of time. The question which presses is, what material will you adopt now? Mr. BAILY wished to have bronze, and a number of bronze bars are made. I have had half a dozen bars of several materials, viz. cast steel, cast iron, Swedish iron, and Low Moor iron: I ordered some of copper, but the casting failed; Mr. DONKIN has however given me a copper bar. I propose to keep all the bases of any measure which may be made in the hands of the Committee, so as to have the whole subject accessible, and to preserve the power of completing it.

“If the Committee will specify the material, my mode of proceeding will be as follows. Suppose that cast steel were proposed. I should take a steel bar, mark the divisions determining a yard pretty nearly, find its expansion; compare it with other authorities, and then define the yard in terms of it.

“Having thus done, I should direct the artist to make me five copies, *mutatis mutandis*, as near as might be to the definitive yard. These copies would be the Standard and four Parliamentary copies A, B, C, D. I should now make a very careful comparison of the primary Standard with my generator, and also with A, B, C, D. The Standard and A, B, C, D may now go to the Government for legislation or adoption, and for conservation. The *generator* I should retain, and upon this should found all my future inquiries, and in fact all copies for publication. The process is the same whatever metal is employed, and in each metal I propose to have a scale and a pendulum, for perpetuation and for comparison with other measures.

“If the Committee will determine as to the metal and the authority for the length, I

think I need give them little trouble for some time. But I think it would be better that, for the present, they should confine themselves to the metal.

“If experience should show that there is a manifest advantage in some other metal, I will apply to them again for direction.

“With regard to the authority for length, I must own that I do not think the comparison with former measures (except the 10-foot and 6-inch Ordnance bars) of much value; or that the Parliamentary Standards will be of much use. But I rely upon being able to furnish at small trouble and no great cost, measures which shall have a given relation to a certain measure within $\frac{1}{50,000}$ th of an inch, and which can be perpetuated without much risk. I expect to produce a standard yard per day, by devoting an hour and a half or two hours to the readings of one bar and the adjustment of a second in its box; which second is to be compared next day, or in 48 hours, and have its place taken by a third.”

The Committee then inspected sundry apparatus under the guidance of Mr. SHEEP-SHANKS.

First, in one of the chambers of the floor next below the ground floor, they inspected the comparing apparatus of the Royal Astronomical Society; being that which Mr. BAILY had proposed to use for the Parliamentary Standards, &c., and to which attention is called in Mr. SHEEPSHANKS'S communication.

Secondly, they saw the vacuum apparatus for pendulum vibration, consisting of a large brass truncated cone supported by three spreading claws, with proper windows below for observations of vibrations, and with proper agate planes at the top for the support of the knife-edges: the cap closing the top was also exhibited.

Thirdly, in one of the vaults two storeys below the ground floor, they saw the principal parts of the new comparing apparatus. Upon a large low pier surmounted by a stone are planted two stone pillars, carrying a connecting top stone, and two stones crossing it; to these crossing stones the microscopes are attached; upon the platform there travels a large three-wheeled carriage or moveable platform, upon which is placed the large box (intended to contain the water, &c. by which temperature will be given), in which is a drop-box intended to carry the bars, each in its proper case and supported by its proper lever-frame. The illumination is effected by an Argand lamp placed at a considerable distance, whose light is directed by proper reflectors.

The Committee then resumed. It was then

Resolved,—That the Committee approve entirely of the course followed by Mr. SHEEPSHANKS, and request that Mr. AIRY will take measures for the examination and discharge of the instrument-maker's accounts.

The Committee then considered the question of material for the Standard. Mr. AIRY read a private letter from Mr. FARADAY, of which the following is an extract:—“I do not see any reason why a pure metal should be particularly free from internal change of its particles, and on the whole should rather incline to the hard alloy than to soft copper, and yet I hardly know why. I suppose the labour would be too great to lay

down the standard on different metals and substances; and yet the comparison of them might be very important hereafter, for twenty years seem to *do* or *tell* a great deal in relation to Standard measures."

After deliberation it was

Resolved,—That at present the Committee see no reason for departing from their resolution of the 11th of July, 1843—"That the material employed for the construction of the Parliamentary Standard of Length be bell-metal or steel, as Mr. BAILY may think best,"—as explained by Mr. BAILY at the meeting of the 10th of November, 1843, when Mr. BAILY recommended an alloy of copper and tin.

I may here appropriately give some description of the apparatus which Mr. SHEEP-SHANKS employed.

First, for the thermometers. The apparatus for the freezing-point (the usual small vessel for containing pounded ice or snow, admitting of drainage of superfluous water), and the apparatus for the boiling-point (a small covered saucepan, with a mercurial gauge, and a hole for the thermometer-stalk), require no further description. In the operations for breaking the column of quicksilver, Mr. SHEEPSHANKS never trusted to subdividing the graduations of the thermometer-tube by eye. The tube was laid in a horizontal position; and a microscope pointing downwards, mounted in a frame which admitted of horizontal motion above the tube, was directed successively to each end of the column of quicksilver; and at each end three readings of the microscope-micrometer were taken, namely, one for the end of the quicksilver-column, and one for each of the graduations preceding and following that end of the quicksilver. A numerical computation was then required for determining the fractional part of the tube-graduation corresponding to the position of the end of the quicksilver-column. This operation, though very exact, occupied much time; it might without doubt have been facilitated by proper mechanical arrangements, of which however Mr. SHEEPSHANKS never availed himself.

Secondly, for the comparison of 3-foot bars. The apparatus established in the cellar of the Royal Astronomical Society's Apartments in Somerset House will be understood from the diagrams in Plates XXVIII., XXIX. and XXX., to which the following explanations apply.

Figure 1, Plate XXVIII., is a ground-plan of the apparatus. The trough for enclosing the case which actually contained the bars is entirely omitted. The observer's station (or what may be considered the front of the apparatus) is the lower part of the diagram.

A, A, &c. is a wooden enclosure, covering the back and (partially) the sides, and extending from the floor nearly to the ceiling of the room.

B, B, &c. is the general platform of masonry.

C, C are the two stone piers.

D, D, a horizontal slab extending right and left; resting on the top of the piers.

EE, EE, two solid transoms of stone, resting upon DD; they carry the two microscopes.

FF, a slab resting upon the two transoms.

G, G, the two micrometer-microscopes. They pass through channels cut in the sides of the transoms; each is carried by two horizontal Y's which are cemented into the back of the channel, and is pressed into the Y's by bars of brass whose ends are fixed by screws to the points of the Y's.

H, H are two lamps for throwing light upon the reflectors of the microscopes, and thus illuminating the defining-points of the standards under observation.

II, II, two perforations in the slab DD, through which the light of the lamps passes to the microscope-reflectors.

J, J, narrow plates of brass, attached I believe for no other purpose than to support the plates, which cover the open side of the channels in which the microscopes are fixed, and which protect the microscope-tubes from violence and from radiation.

KK, KK, broad plates of brass below the transoms, which I believe were intended to intercept radiation between the transoms and the standards.

L, L, cords which supported the plates K.

M, the great travelling platform, on which the box carrying the standards was placed. The box is not shown in this diagram.

N, N, the two side-wheels of the travelling platform.

O, their common axletree.

P, the tail of the travelling platform, with a wheel below its end, which is not seen in this diagram. This wheel, as well as N, N, roll on the masonry B.

Q, Q, Q, Q, four screws for vertical adjustment of the box which is placed on the platform.

R, R, R, R, four screws for lateral adjustment of the box.

S, S, two screws for longitudinal adjustment of the box. They were sometimes turned by hook's-joint handles.

T, T, &c., eyes for the fixing of cords, for conveniently raising the platform.

Figure 2 is a front view of the apparatus.

D' is a small block of stone cemented to D and to E, apparently to connect them more firmly.

E' is a larger block cemented to D and to both the transoms E, apparently for the same purpose.

The Y's which carry the microscopes G are shown (concealed by stone) in this view.

U is the third wheel of the travelling platform, carried by its tail P.

V is the large cast-iron box or water-trough carried by the platform; which was nearly filled with water, and into which was dropped the box containing the Standards to be compared.

W, eyes for the fixing of cords.

X, a tap for the discharge of the water.

Figure 3, Plate XXIX., is a side view of the apparatus.

J' is the plate which covers the microscope-tube.

The bars which press the microscope-tube into the Y's are shown in this view, concealed only by the plate J'.

Figure 4 is a plan of the water-trough, as mounted on the platform, and carrying the drop-box, in which the two Standards to be compared are supposed to be placed.

The upper surface V of the water-trough is cast in a pannelled form.

Y is the drop-box, made of brass, resting by its flanges all round upon the upper surface of V.

Z is the cover of the drop-box.

a, a are two handles of the cover.

b, b are two long slits, for observing the stalks of two thermometers enclosed in the drop-box.

b', b', two slits through which light is thrown from the upper reflecting prism to the lower reflecting prism, to illuminate the thermometer-scales.

c, c, c, c are four holes, through which the defining points of two Standards are viewed by the microscopes G.

Figure 5 is a longitudinal section of the water-trough, the drop-box, and the quicksilver-box, showing one of the bars as partially floating in the quicksilver, for observation with the microscopes. (The bars intended to be placed in quicksilver were all covered with gold-beater's skin.)

d, d are two blocks supporting the quicksilver-box.

e is the quicksilver-box of cast iron.

f is a swinging stirrup, on which the middle of the bar rests very slightly.

g, g, adjusting screws which act on the immediate support of f.

h, the Standard Bar under observation, floating almost freely in the quicksilver.

i, i, the well-holes in the bar, sunk to the depth of half its thickness; in the bottom of each well-hole is fixed a gold pin, on the surface of which the defining mark is traced. In all the bars ultimately constructed by Mr. SHEEPHANKS, the defining mark is a fine line, transversal to the bar; accompanied by two lines parallel to it, one on each side at the distance 0.01 inch; which were intended to give the means of ascertaining the value of the divisions of the micrometer. There are also two longitudinal lines; and the point of the transversal line intended to define the Standard Measure is that which is midway between the longitudinal lines.

j, j, two bent thermometers. It is to be remarked that there is a longitudinal partition in the quicksilver-box, and that two large and deep notches are cut in this partition, in which the bulbs of the thermometers are lodged, and through which the quicksilver flows. The stalks of the thermometers rest on the edge of the partition. (In a few bars, holes were sunk in the bars themselves, and bent thermometers with small bulbs were placed in these holes, in quicksilver, I believe).

j', j', two long rectangular glass prisms, for turning a beam of light, thrown vertically through the slits b', b', into a horizontal direction, by internal total reflexion, in order to illuminate the thermometers jj.

j'', j'', two paper cards in an inclined position, beyond and below the thermometers, upon which was thrown the beam of light passing horizontally from j', j', and which formed a white ground for the vertical view of the thermometer-tubes.

Figure 6, Plate XXX., is merely an enlarged view of the adjustment of the stirrup-support in figure 5.

Figure 7 is a transversal section of the water-trough, drop-box, quicksilver-box, and bars.

k is the longitudinal partition of the quicksilver-box.

Figure 8 is a plan of two standards as placed in the quicksilver-trough for comparison. In figure 4 they are concealed by the cover Z.

Figure 9 is an enlarged plan of the adjustment of the stirrup-supports in figure 8.

Figure 10 is a longitudinal section of the mounting employed when the standard-bars are supported by "block-and-stirrup."

l is a block, planted on the platform M.

m, a wooden box.

n, n, two blocks.

o, a brass plate resting upon them.

p, a small metallic block (with foot-screws), on which the standard-bar immediately rests. This is the "block" of the "block-and-stirrup" apparatus.

q, one of two uprights supported by a pedestal similar to that of p.

r, a stirrup swinging with pivots on the top of q. This is the "stirrup" of the "block-and-stirrup" apparatus. The standard-bar rests in this stirrup.

Figure 11 is a plan of the instrumental arrangement for the comparison of the length of one standard-bar defined by line-measure with the sum of the lengths of two sections of two standard-bars defined by end-measure. The principle concerned in this operation will be explained in the latter part of this Memoir.

s and t are two end-bars, with their ends in contact. The line-bar h, and each of the end-bars s and t, is supported upon a lever-frame, to be described shortly.

w, w, &c. are collets, fixed near the extremities of the end-bars by stiff-friction only.

x, x are spiral springs attached to the collets, drawing the ends of the bars into contact, with a pressure of about 3 lbs.

Figure 12 is a longitudinal section of the same arrangement, showing however only the two end-bars upon their lever-frames.

v, v, v, v are insertions of pieces of agate in the ends of the metallic bars.

For understanding of the supporting-mechanism, it must be remarked that each bar rests upon two lever-frames; and that the form of each lever-frame is the following. The foundation-block supports the centre of motion at the centre of the length of a lever of first order; this lever consists of two parallel plates separated by a much larger space than the breadth of the bar, and the parallel plates are tied by cross-ties. This lever carries the two centres of motions of two similar but smaller levers of second order, each consisting of two parallel plates, falling between the parallel plates of the lever of

first order, but yet more widely separated than the breadth of the bar. Each lever of second order carries two rollers, upon which the standard-bar rests.

y is the support of a lever of first order.

z, z, the cross-ties of a lever of first order.

a, a, the centres of motion of levers of second order.

b, b, the cross-ties of a lever of second order.

c, c, the rollers carried by a lever of second order, on which the standard-bar immediately rests.

It will be seen that the pressures on the four different rollers *c, c, c, c*, carried by one lever-frame, are necessarily equal; and that if the two lever-frames are planted symmetrically under the bar, the pressures on the eight different rollers are necessarily equal.

Figure 13 contains a view and section, on an enlarged scale, of the ends of two end-bars in contact. The inclined lines show how the angles of the square bar are chamfered off so as to form an octagon; which is turned at the extremity into a cylindrical form.

Figure 14 represents the microscope commonly employed to read the graduations of the thermometers. The small pieces at the bottom of the frame embraced the edge of the flange of the drop-box, permitting the frame to slide longitudinally. The mode of illuminating the thermometer-tubes will be understood from this figure: *d* is a small hand-lamp, by which light was thrown horizontally into the reflecting prism *e*. By this reflexion, the light was thrown downwards upon the reflecting prism *j'*; and by the second reflexion the light was thrown horizontally upon the inclined card *j''*, which served as a ground under the thermometer-tube *j* when viewed by the microscope from above. In order to facilitate the reading of the comb in the field of view, a card *f'* was mounted, which, when the micrometer-wire had been brought to the end of the column of quicksilver or to the nearest division on the tube, was inclined to the position *f''*, and received the light of the lamp, and fully illuminated the field of view.

This, perhaps, will be a proper place for inserting a memorandum by Mr. W. SIMMS, Jun., on Mr. SHEEPSHANKS' practice in observing the Standard Yards, with which Mr. W. SIMMS favoured me after the death of Mr. SHEEPSHANKS:—

“The two bars to be compared were placed upon their supports within the trough, at a distance of about 2 inches between their centres, and as nearly parallel as practicable, care being taken that each division should pass nearly under the axis of the micrometer-microscope when the trough was wheeled up to its place.

“There is a considerable amount of adjustment provided in the trough-carriage; but Mr. SHEEPSHANKS preferred having the apparatus so carefully arranged, that but little adjustment might be required at the time of comparison.

“I believe no observations were ever made on the same day on which the bars were arranged; I frequently placed them for Mr. SHEEPSHANKS in the evening, and he observed the following day; so that generally eighteen hours were allowed to intervene at the least. The trough was always covered up when left, small shutters being placed over the holes in the covers through which the divisions were seen.

“The observations were made thus. The trough [upon the travelling platform M] being wheeled by the hand, so as to bring the divisions on one of the bars under the micrometers, the trough-adjusting screws were used finally to adjust the division, so that the micrometer-readings should be on opposite sides of the zero and nearly to an equal amount: three readings were now taken of A [one of the microscopes], and entered together; then three of B [the other microscope] were made and registered; three more of B under these; and finally, three of A. Mr. SHEEPSHANKS considered this method of registering six observations of each division to be a check upon any start which might take place in the apparatus; and three readings were easily kept in memory, so that they could be written down at once.

“The trough being wheeled up, and the other bar being similarly adjusted by the trough-adjusting screws, the micrometer-readings were taken in precisely the same manner.

“The lamps were then changed; that which illuminated micrometer A being applied to B, and *vice versa*.

“The trough remaining undisturbed, a similar set of observations were made of the same bar, a slight change of reading being frequently found to arise from a change of light. Then the first bar was brought up to position and observed. This completed a set.

“At an early period of the observations the bars were made to change places in the trough, and another set was taken the following day, as Mr. SHEEPSHANKS considered that the position of the trough might affect the distance between the micrometers.

“In Mr. SHEEPSHANKS’ register of observations, the bar marked ‘inwards’ is that farthest from the observer.

“At a later period the bar of comparison was left undisturbed, and a number of other bars was compared with it; then that bar was placed in the other position, and the comparisons again made; this was to avoid having to arrange two bars every time.

“Mr. SHEEPSHANKS commonly made several sets of observations at one visit, but each set was always kept separate.”

SECTION V.—*Proceedings of Mr. SHEEPSHANKS to the middle of 1850; preparation of Thermometers; adoption and rejection of “Brass 2” as Basis for the new Standard Yard; adoption and rejection of “Split Plug A;” adoption of “Bronze 12;” experiments on thermometric expansion; comparison of Bronze 12 with several bars; first suspicion of personal equation; rejection of Bronze 12 as Basis, and final adoption of “Bronze 28.”*

I now commence an account of the measures made by Mr. SHEEPSHANKS with the various apparatus which I have described. And here I must state generally, that the magnitude of the work makes it impossible for me to enter into great details. From actual numeration of a large portion of the observations, and from estimation of the rest, I find that the number of micrometer-readings amounts to nearly two hundred thousand. I can therefore only give abstracts or results.

The work which obviously was first to be undertaken, was the preparation of thermometers. It will be convenient here to describe all that was done, to the time of Mr. SHEEPSHANKS'S death.

Thermometers were procured, generally in Series of twelve at a time, and each Series was distinguished by a letter or mark; as A, B, C, Flat S, Flat Bore, Flat Notched, Round Bore, Round Notched, Long S, Bent. After all destruction by breaking, the number of thermometers still in my hands is 66. It was, I suppose, the intention of Mr. SHEEPSHANKS, that each of the Standards which he proposed to construct should be accompanied by a thermometer. Of these thermometers, a few were never examined at all; but the greater part were examined, some for the freezing-point, some for the boiling-point, some for the subdivision, some for two or all three of these elements. Some were merely compared with others of the series whose errors were determined by the original process (as, being intended for use through a limited range of temperature, they did not admit of independent determination of the boiling-point).

The following thermometers, still remaining, were completely corrected by the original process:—A, 2, 5, 6, 8, 9; Long S, 1, 2, 3, 6. The following were corrected by comparison:—B, 4, 5, 6, 7, 8, 9, 10; C, 1, 2, 4, 6, 7, 8, 9, 10; Flat S, 1, 2, 3, 5, 7 (all by comparison with A, 8, 9); Flat S, 6, 8; Flat Bore, 1, 2; Bent, *l*, *s*; also BAILY'S A (by comparison with others of the A series); Flat S, 9, 10, 11, 12 (by several of the A series and several of the Long S series); Bent, 0 Notch, 2 Notches (by comparison with the whole of the A series and the whole of the Long S series). The thermometers described as Bent 0 Notch and Bent 2 Notches are otherwise marked R and L, and are the thermometers which were inserted in the quicksilver trough, and on which in fact almost the whole of Mr. SHEEPSHANKS'S operations in the comparison of his own standards depend, so far as they are influenced by temperature. In some few instances, however, the temperatures depend on *l* and *s* (bent thermometers with small bulbs which were inserted in holes in the bars). The freezing-points and the inequality of graduations of L, R, *l*, *s* were determined independently, but not the boiling-points.

I am inclined to think that the papers containing some of the early comparisons of thermometers have never reached me. Thus it would appear that for Mr. SHEEPSHANKS'S "Statement," dated 1848, July 18, some comparisons of the Ordnance Bar Thermometers and of BAILY'S Thermometer A must have been made; but I find none, in the papers which I possess, anterior to 1855. Even for the important thermometers L and R, I find no comparisons anterior to 1850. In one of Mr. SHEEPSHANKS'S papers I find mention of "two good old thermometers," and I conjecture that comparisons had been made with some thermometers supposed to possess superior authenticity.

It would seem that, as soon as some progress was made in the preparation of thermometers, Mr. SHEEPSHANKS proceeded to determine the value of one new bar, in terms of the Lost Imperial Standard. The bar first employed for this purpose was called by him "Brass 2." This bar was compared with SHUCKBURGH'S Scale, the Royal Society's Standard, and the Ordnance Standards, and with others not essential to the present

purpose. To facilitate the comparison with the Ordnance Standards, two bars of wrought iron (Low Moor and Swedish) were prepared, similar in form to the bronze and brass bars, and were used as intermediaries; some comparisons were however made directly with the Ordnance Bars. Then it was necessary to express the length of SHUCKBURGH'S Scale and of the Royal Society's and Ordnance Standards in terms of the Lost Imperial Standard. For SHUCKBURGH'S and the Royal Society's Scale, Mr. SHEEPSHANKS adopted KATER'S and BAILY'S values. For the Ordnance Bars, a very troublesome investigation was undertaken. On account of the difference of metal, it was necessary to examine the graduation of the thermometers; and the result was, that MURPHY'S thermometer L required the correction $-1^{\circ}12$, MURPHY'S R $-0^{\circ}95$, 1A $+0^{\circ}7$, and 2A $-0^{\circ}4$. BAILY'S thermometer appeared nearly correct. Then there was a discussion, at great length, of the personal equations of the different observers, in the observation of the different dots of the Imperial Standard, and of the Ordnance Standards. Long study would be necessary to enable any person to exhibit all the steps of these operations in a clear and logical form. The values which Mr. SHEEPSHANKS appears to have adopted for the lengths of the two Ordnance Bars in terms of the Imperial Standard, at the temperature 62° FAHRENHEIT, are 1A = 35.999716 inches, 2A = 35.999892 inches. Finally, from these various sources, Mr. SHEEPSHANKS inferred the value of Brass 2, and communicated it to the Members of the Committee in the following paper.

“Statement of the means employed for obtaining an Authentic Copy of the Lost Imperial Standard Yard. By the Rev. R. SHEEPSHANKS.

“As I have now completed the first set of observations for restoring the lost Standard, I wish to present the results to the Committee.

“I have taken a brass bar (marked No. 2) as my term of comparison. This is held by its middle, and floats as nearly as possible in mercury. The comparisons have been made carefully with the best *primary* evidence of the lost Imperial Standard.

“I am very much surprised, and not a little mortified, that this evidence should be so scanty; still I trust that it is sufficient for my purpose, which is simply to procure a copy of the Imperial Standard, which is at least as accurate as any results derived from, or referred to it. A short notice of our measures of length will not be out of place.

“All the accurate scales which have been made within the last hundred years can be traced back, errors excepted, to the yard laid off by GRAHAM, on a bar made for the Royal Society in 1742. I shall call this GRAHAM'S bar, to distinguish it from other scales belonging to the same Society. Upon this bar, GRAHAM laid down a yard taken from a Standard kept at the Tower (this yard is marked E on GRAHAM'S bar, and is called by me GRAHAM'S *Tower Yard E*), but not with any particular care*; and when

* It is stated in the Philosophical Transactions, 1742-3, p. 185, that “Mr. GRAHAM did with the greatest care lay off the length of three English feet from the Standard of a Yard kept in the Tower of London.” As the Tower Standard was a flat scale, this could be done with great accuracy. When both were compared

the authority of this original yard was called in question, he laid down, subsequently, a second yard marked *Excheq.*, which he took with great care* from an old Standard of Elizabeth kept at the Exchequer as the legal Standard. These two yards were found by GRAHAM to be thus related:—

$$\text{Tower Yard E} = \text{Exchequer Yard } \textit{Excheq.} + 0^{\text{in}} \cdot 0075.$$

“This Tower Yard E is generally called the ‘Royal Society’s Standard Yard,’ by the earlier authorities.

“I do not know when BIRD made his original scale, but from his method of dividing mural quadrants, a well-divided scale must, I think, have been in his possession before the graduation of the Greenwich Mural Quadrant. In 1758 and 1760, he made two Standard bars for a Committee of the House, which are known by those dates, the Standard of 1760 being in 1821 declared to be the legal Imperial Standard, which I am attempting to restore. I find, from some notices by MASKELYNE, in the Philosophical Transactions for 1768, pp. 324, &c., that BIRD’s *own* scale was just $0^{\text{in}} \cdot 001$ in 3 feet *shorter* than GRAHAM’s Tower Yard E†; and I believe, though I have no absolute evidence of the fact, that his own scale was the type followed by BIRD in constructing his Standards of 1758 and 1760, and in fact all the scales which issued from his hands; so that BIRD’s scales are, errors excepted, $0^{\text{in}} \cdot 001$ shorter than GRAHAM’s Tower Yard E. It is certain that TROUGHTON, in laying down his own scale, took the fundamental length from a scale by BIRD (Philosophical Transactions, 1798, p. 137). Hence, as a general rule, all scales, having BIRD or TROUGHTON for their authors, will be found to be about $0^{\text{in}} \cdot 001$ shorter in 36 inches than GRAHAM’s Tower Yard E; although accidental errors, to half that amount at least, may occur in any of the older scales which have been examined by SHUCKBURGH, KATER, &c.

“If this account be, in the main, correct, we see how it comes to pass that SHUCKBURGH’s scale by TROUGHTON should be *nearly* of the same length as BIRD’s Standard of 1758 and 1760, since they are all of the same family. The statements of SHUCKBURGH and KATER as to the *identity* of the measures must be qualified, and TROUGHTON’s belief in the perfection and similarity of his own scales cannot be fully admitted‡.

“Another family of scales, viz. General ROY’s scale and RAMSDEN’s scale, are said to have been carefully compared with GRAHAM’s Tower Yard E, and to have agreed *exactly*

with the Exchequer Standard, pages 548 and 550, their difference appeared to be $0^{\text{in}} \cdot 0111 - 0^{\text{in}} \cdot 0075 = 0^{\text{in}} \cdot 0036$. But the Exchequer Standard (a rude end-standard) could not be very exactly compared; and it seems probable that the origin of the discordance is not in the inaccuracy of the transfer, but in the inaccuracy of comparison through the Exchequer Standard.—G. B. A.

* That is, with as great care as the nature of the case permitted. The construction of the Exchequer Standard did not admit of accurate transfer.—G. B. A.

† “These are not MASKELYNE’s very words, but his meaning applied to my own nomenclature.”

‡ “From SHUCKBURGH’s measures of the 6-inch spaces of his scale, we may gather that the yard $0^{\text{in}} \dots 36^{\text{in}}$ exceeded the yard $6^{\text{in}} \dots 42^{\text{in}}$ about $0^{\text{in}} \cdot 00045$, and the 6-inch space $30^{\text{in}} \dots 36^{\text{in}}$ exceeded the 6-inch space $36^{\text{in}} \dots 42^{\text{in}}$ by $0^{\text{in}} \cdot 00053$.”

with it. From these scales, the measuring apparatus was constructed, with which the bases of the English Trigonometrical Survey were determined. I refer to KATER's Memoir, Philosophical Transactions, 1821, p. 75, and to Appendix No. 1, with respect to this operation.

“RAMSDEN'S scale is lost. ROY'S scale was compared by Sir G. SHUCKBURGH with his own scale, very unsatisfactorily*, and KATER has shown the result to be worthless. KATER'S comparison, in 1821, agrees very well with ROY'S own account of it, viz. that it was made for GRAHAM, who would probably follow his own Tower Yard E more scrupulously than BIRD thought it necessary to do. I have not compared ROY'S scale, as I consider KATER'S comparisons with the Imperial Standard in 1821 not satisfactory by his own showing in the Memoirs of 1826 and 1830: BAILY did not compare ROY'S scale at all with the Imperial Standard.

“I have not looked after KATER'S standards of 1826, because they only profess to be exact copies of SHUCKBURGH'S scale, and he has thrown doubt on the relation of SHUCKBURGH to the Imperial Standard in his memoir of 1830. I object strongly to his mode of measurement, *i. e.* resting the apparatus upon the scale to be measured. On this account also I reject DOLLOND'S scale, though it was compared directly with the Imperial Standard. The most favourable type of KATER'S yard is the scale which he made for the Royal Society in 1831.

“The Royal Astronomical Society's tubular scale, and two other scales of the same construction for the Danish and Russian governments, were compared by BAILY with the Imperial Standard. I give, in Appendix No. 2, reasons why I have not admitted the Royal Astronomical Society's scale in these comparisons.

“The scales I have actually compared with the Brass bar No. 2 are as follows:—

	in. in.
Sir G. SHUCKBURGH'S scale.	0—36
Sir G. SHUCKBURGH'S scale.	10—46
All on the same bar	{
	GRAHAM'S Tower Yard E.
	GRAHAM'S Exchequer Yard.
	Yard nearly same as E, but anonymous.
	KATER'S Royal Society's scale.
	Ordnance Iron Bar, A1.
	Ordnance Iron Bar, A2.

“The direct comparisons with the Imperial Standard made by BAILY and others in 1834 are not very satisfactory. The comparisons between the Imperial Standard and

* “He compares the successive feet of ROY with the 12 inches of his own scale, 12^{in.} . . . 24^{in.}, and finds, assuming his own foot to be correct, that

$$\text{ROY 36 inches} = 35^{\text{in.}} \cdot 9999 \text{ SHUCKBURGH.}$$

But this foot is, according to his own account, less by 0^{in.}·00006 than the mean foot of his scale, and less by 0^{in.}·00013 than the mean foot of the yard from 0^{in.} . . . 36^{in.}. He also says, p. 178, that

$$\text{ROY 42 inches} = 42^{\text{in.}} \cdot 00010 \text{ of SHUCKBURGH.}$$

KATER, on the contrary, makes ROY 36 inches = SHUCKBURGH 36^{in.}·0009, and is, I doubt not, nearly right.”

SHUCKBURGH'S scale are not very numerous nor very consistent. Those between the Imperial Standard and the Ordnance iron bars, A1 and A2, are singularly discordant.

"I ought to mention that I selected my terms of comparison with the Imperial Standard, *à priori*, on my own opinion of their value from their history. I have not compared any scale which appeared to me suspected, for I should not have known how to estimate the weight, and mere discordance would not have justified rejection.

"Some details and some steps of my comparisons will be found in the Appendix No. 3. From these I deduce the following approximate value of the lost Standard:—

"1st. From SHUCKBURGH'S scale 10^{in.} . . 46^{in.}:—

$$\begin{array}{r} \text{Brass bar 2=SHUCK. 10} \begin{array}{c} \text{in.} \\ \text{---} \\ \text{46} \end{array} \begin{array}{c} \text{in.} \\ \text{---} \\ \text{0.000222} \end{array}, 100 \text{ Obs. (Appendix No. 3.)} \\ \text{SHUCK. 10}^{\text{in.}} \text{---} \text{46}^{\text{in.}} \text{=Imp. Stand.} \quad \begin{array}{c} \text{---} \\ \text{+0.000058} \end{array} \quad (\text{Mem. R. A. S. vol. ix. p. 120.}) \\ \therefore \text{Brass bar 2=Imp. Stand.} \quad \begin{array}{c} \text{---} \\ \text{+0.000280} \end{array} \end{array}$$

"2nd. From SHUCKBURGH'S scale 0^{in.} . . 36^{in.}:—

$$\begin{array}{r} \text{Brass bar 2=SHUCK. 0} \begin{array}{c} \text{in.} \\ \text{---} \\ \text{36} \end{array} \begin{array}{c} \text{in.} \\ \text{---} \\ \text{0.000006} \end{array}, 120 \text{ Obs. (Appendix No. 3.)} \\ \text{SHUCK. 0}^{\text{in.}} \text{---} \text{36}^{\text{in.}} \text{=Imp. Stand.} \quad \begin{array}{c} \text{---} \\ \text{+0.000090} \end{array} \quad (\text{Phil. Trans. 1830, p. 377.}) \\ \therefore \text{Brass bar 2=Imp. Stand.} \quad \begin{array}{c} \text{---} \\ \text{+0.000084} \end{array} \end{array}$$

"I have taken KATER'S last value as most worthy of confidence, but I do not much trust it, on account of the objectionable mode of resting the microscope apparatus upon the scale.

"3rd. From KATER'S scale, made for the Royal Society 1831:—

$$\begin{array}{r} \text{Brass bar 2=KATER'S scale 36} \begin{array}{c} \text{in.} \\ \text{---} \\ \text{36} \end{array} \begin{array}{c} \text{in.} \\ \text{---} \\ \text{0.000849} \end{array}, 110 \text{ bisections.} \\ \text{KATER'S scale 36}^{\text{in.}} \text{=} \begin{array}{c} \text{---} \\ \text{35.999380} \end{array} \quad (\text{Phil. Trans. 1831.}) \\ \therefore \text{Brass bar 2=} \begin{array}{c} \text{---} \\ \text{36.000229} \end{array} \end{array}$$

"I have given the values of Brass bar 2 in terms of Imperial Standard from comparisons with A1 and A2 in Appendix No. 3.

$$\begin{array}{r} \text{"Hence Brass bar 2=36.000280 by SHUCKBURGH 10} \begin{array}{c} \text{in.} \\ \text{---} \\ \text{46} \end{array} \text{ and comparisons in 1834,} \\ \quad \text{= .000084 SHUCKBURGH 0} \begin{array}{c} \text{in.} \\ \text{---} \\ \text{36} \end{array} \text{ and KATER'S authority.} \\ \quad \text{= .000229 KATER'S scale.} \\ \quad \text{= .000303 A1, compared in 1834.} \\ \quad \text{= .000275 A2, compared in 1834.} \\ \quad \text{= 36.000234 by a mean of all.} \end{array}$$

"This should be pretty near the truth; but I prefer 36.00025, if in such a matter such a difference be worth notice.

"I propose, therefore, in constructing the new standards, to assume that

Brass bar 2=36^{in.}.00025 of lost Imperial Standard at 62° FAHRENHEIT,
and to make that the base of my future proceedings.

"July 18, 1848.

"R. SHEEPHANKS.

“ APPENDIX No. 1.

“ *On the Scales used in the Trigonometrical Survey, and especially ROY’S Scale.*

“ The Irish Survey depends on a base which is ultimately referred to an iron bar of 10 feet, and a brass bar of 6 inches. These were laid off, I believe, from the 5-foot brass measures of TROUGHTON or SHUCKBURGH, as nearly as could be readily managed, but they have no *immediate* relation to any *yard*, standard, or otherwise. It will be necessary to ascertain the value of these units in terms of the new standard, when that is fixed; but there is nothing to be extracted from them which would assist us in restoring the Imperial Standard destroyed in 1834.

“ At first sight, one might have expected some help from the scales employed in the English Survey, viz. from ROY’S scale and RAMSDEN’S scale, which were, or were intended to be, the units of the bases of Hounslow Heath, Romney Marsh, &c.; but a careful examination of the memoirs relating to those bases, and of KATER’S memoir (Philosophical Transactions, 1821, p. 75), extinguishes hope of any aid from this quarter.

“ ROY’S scale (Philosophical Transactions, vol. lxxv. p. 401) was purchased by him at SHORT’S sale. ‘ It was originally the property of the late Mr. GRAHAM, the celebrated watchmaker; has the name of JONATHAN SISSON engraved upon it, but is known to have been divided by the late Mr. BIRD*, who then worked with SISSON.’ ROY, aided by RAMSDEN, found that 36 inches, taken from ‘ GRAHAM’S Tower Yard E,’ exactly reached to 36 inches on his scale, the temperature being 65°. GRAHAM’S Exchequer Yard was found 0^m·0069 shorter. From the 40 inches of ROY’S scale, the deal rods and glass rods used by ROY in measuring the Hounslow Heath base were laid off, not directly, but by 40-inch spaces marked off on a large plank. By these points laid down on the large plank, the chain used in the Romney Marsh base was verified.

“ RAMSDEN’S scale was also compared with GRAHAM’S Tower Yard E, ‘ when they were found to be precisely of the same length.’—Philosophical Transactions, 1795, p. 435. This must have been a comparison of 36 inches only. From his own scale, RAMSDEN laid off 40-inch spaces on the 21-foot iron bar which he used for ascertaining the actual lengths of the chains A and B, by which the base of Hounslow Heath was remeasured, &c.

“ If, then, the operations had been correctly performed, all the base measurements of the English Ordnance Survey would have been expressed in terms of GRAHAM’S Tower Yard E.

“ But it is impossible to trust, implicitly, random expressions that two measures *agree exactly*: this cannot be ascertained by a beam compass. ROY and RAMSDEN are both silent as to the manner in which they ascertained the relation of their 40 inches to 36 inches; and KATER’S account of the 21-foot iron bar does not give a very high idea of RAMSDEN’S exactness in transferring his 40-inch spaces to his iron bar. (See his memoir, Philosophical Transactions, 1821, p. 71.) Thus, according to KATER,—

* “ The fundamental length was very probably laid off by GRAHAM himself.”

“ROY's scale, 36 inches= $\overset{\text{in.}}{\text{GRAHAM'S Tower Yard E}}-0\cdot00047$, which is pretty well.

“But a mean yard of RAMSDEN's bar= $\text{GRAHAM'S Tower Yard E}+0\cdot00114$.

“ROY's yard, according to KATER, is about $0^{\text{in}}\cdot0009$ longer than the Imperial Standard.

“In fixing the Imperial Standard, KATER very wisely, I think, dismissed all the supposed units of the Survey. RAMSDEN's scale is lost; and I have not used ROY because it has no independent value,—professing merely to be a copy of GRAHAM's Tower Yard;—because the comparisons made of it by SHUCKBURGH are very indifferent and inaccurate; and because those by KATER in 1821 are inferior in number, and very inferior in quality, to those made by him in 1831 between the Imperial Standard and the Scale of the Royal Society, which I consider his most complete work in linear measurement.

“APPENDIX No. 2.

“*The Royal Astronomical Society's Scale and the Tubular Scales discussed.*

(The purport of these remarks has already been given.)

“APPENDIX No. 3.

“*Comparisons between Brass Bar 2 and other Scales.*”

(These are now unnecessary.)

MR. SHEEPHANKS now commenced comparisons of Brass 2 with several Bronze bars, but was much distressed by the imperfect definition and varying position of the defining lines, as viewed under the microscopes. Numerous attempts were made to correct these faults; at length, recourse was had to another construction which he called “Split-Plug.” Instead of cutting the line upon the end of a gold pin, a plug of gold, included in one of bronze, was split longitudinally; the surfaces of separation were smoothed; the two halves of the plug (each half consisting of two metals) were then united by pins; the compound plug was forced from below into a hole of the bar; and its end was ground off level with the bottom of the well, and was polished. The division of the gold plug presented a well-defined dark line, scarcely affected by change in the direction of the light. It appears to have been first used on 1849, March 12. But about the same time another improvement was made, namely, the use of pierced glass prisms instead of annular mirrors, for reflecting the light of the lamps upon the defining lines. The custom was also introduced of interchanging the lamps after every series of observations. These innovations seem to have been so far satisfactory, that no desire was afterwards entertained to extend or retain the use of the Split-Plug.

Split-Plug A was however compared fourteen times (five observations in each series) with Brass 2 between 1849, March 12, and May 14; the mean gave

At temperature $49^{\circ}\cdot 1$, Split-Plug A= $\text{Brass 2}+0^{\text{rev}}\cdot 1044$.

One revolution = $0^{\text{in}}\cdot 00370$.

Split-Plug A was then used as a bar of reference with which fourteen bronze bars were compared.

It was also compared directly with the Royal Society's Scale; but the result of this direct comparison, $36^{\text{in}}\cdot000485$, did not exactly agree with that of the indirect comparison through Brass 2. After remarking this discordance, Mr. SHEEPSHANKS adds, "There was another objection to making the split-plug bar my standard. The construction is not mechanically sound; the difference from the true yard leaves too much influence to the micrometer; and I have upon it no scale by which I can control the micrometer. I found too that by my better arrangement of the light, the superiority of the split-plug was no longer evident. So I looked over the values of my bars compared with Split-Plug A, and selected Bronze 12 as generating standard to which everything is to be referred."

After this decision, no farther use was made of the results of comparisons of bars with Split-Plug A. The divided plugs were removed from A and from another of similar construction called Split-Plug B, and they were then fitted with gold plugs and incised lines in the same manner as the others, and were called Bronze 39 and Bronze 40.

In the month of September 1849 Mr. SHEEPSHANKS proceeded to compare Bronze 12 with the original standards (omitting SHUCKBURGH'S scale). The results are the following:—

$$(1^{\text{r}}=0\cdot003576).$$

$$\begin{aligned} \text{By 100 observations at } 56^{\circ}\cdot04 \text{ FAHR.}, \text{ Bronze 12} &= \text{Ordnance 1A} - 0^{\text{r}}\cdot0582 \\ &= 36^{\text{in}}\cdot000219 \end{aligned}$$

$$\begin{aligned} \text{By 100 observations at } 56^{\circ}\cdot5 \text{ FAHR.}, \text{ Bronze 12} &= \text{Ordnance 2A} - 0^{\text{r}}\cdot1275 \\ &= 36\cdot000093 \end{aligned}$$

Also,

$$\text{By 75 observations, Low Moor A} = \text{Ordnance 1A} + 0^{\text{r}}\cdot0663 = 35\cdot999962$$

$$\text{By 55 observations, Low Moor A} = \text{Ordnance 2A} + 0^{\text{r}}\cdot0102 = 35\cdot999930$$

$$\text{Mean} = 35\cdot999946$$

and

$$\begin{aligned} \text{By 200 obs. (reduced separately) at } 62^{\circ} \text{ FAHR.}, \text{ Bronze 12} &= \text{Low Moor A} + \cdot000149 \\ &= 36\cdot000095 \end{aligned}$$

In a similar way, through a bar of Swedish iron,

$$\text{Bronze 12} = 36\cdot000063$$

$$\text{By 160 observations at } 57^{\circ}\cdot58 \text{ FAHR.}, \text{ Bronze 12} = \text{R. Soc.} + 0^{\text{r}}\cdot1727 = 35\cdot999982.$$

From these, Mr. SHEEPSHANKS concluded

$$\text{Bronze 12} = 36\cdot000043$$

at the fundamental temperature 62° FAHRENHEIT.

(Different reductions gave $36\cdot000034$ and $36\cdot000048$.)

In the winter of 1849–1850 Mr. SHEEPSHANKS made a series of experiments for the thermometric expansions of Bronze, Brass, and Low Moor Iron. The different temperatures were given to the bars by pouring in water at different temperatures into the external box: this, I believe, is the first occasion on which it was so used. The quan-

tity of water employed at once was 11 gallons. The corrections to the thermometers L and R were still obtained, I believe, from old thermometers: but, as the comparison of L and R with new original thermometers followed closely, I am not quite certain on this point. Each number below is the mean of about thirty comparisons:

$$1^{\circ} = 0^{\text{in}} \cdot 003587.$$

For relative expansion of Bronze 12 and Low Moor Iron.

Day, 1849.	Temperature.	Reading for Bronze 12.	Reading for Low Moor Iron.
November 30.... {	68 ^o ·76	r. 201·5598	r. 201·2976
	64·41	201·0627	200·9355
December 1 ... {	51·50	199·8867	200·1899
	58·88	200·5319	200·5998
	57·16	200·3766	200·4895
December 3	67·65	201·3903	201·1642
December 5	78·81	202·5139	201·9086
December 6 ... {	54·82	200·2089	200·4075
	61·15	200·7820	200·7572
December 8 ... {	48·46	199·6225	200·0354
	75·45	202·1233	201·6404
December 10 ... {	68·92	201·5656	201·2943
	64·13	201·0967	200·9797

From these, the excess of expansion of 36 inches of Bronze above Iron for 1° FAHRENHEIT was inferred to be 0^r·03318.

For absolute expansion of Low Moor Iron, Mr. SHEEPSHANKS compared the higher and lower temperatures on each of the following days: Nov. 30, Dec. 1, Dec. 6, Dec. 8, Dec. 10, as given in the last Table. From these he obtained, for 1° FAHRENHEIT, Absolute expansion of 36 inches of Low Moor Iron = 0^r·06095.

For absolute expansion of Bronze 12 and Brass 2.

Day, 1850.	Temperature.	Reading for Bronze 12.	Reading for Brass 2.
January 24..... {	36 ^o ·06	r. 198·8437	r. 198·8780
	51·75	200·3481	200·4152
	67·82	201·8598	201·9467
January 25..... {	70·14	202·0599	202·1320
	45·85	199·7360	199·7850
January 26..... {	41·95	199·2963	199·3419
	70·46	202·0152	202·0959
May 4..... {	54·23	200·0187	200·0701
	65·87	201·1187	201·1719

From these were obtained, for 1° FAHRENHEIT,—

Absolute expansion of 36 inches of Bronze = $0\cdot09507^r$

Absolute expansion of 36 inches of Brass = $0\cdot09601$;

and by combining the absolute expansion of Bronze with the excess of expansion of Bronze above Iron,

Absolute expansion of 36 inches of Iron = $0\cdot06189$.

In the spring of 1850, from February to April, Mr. SHEEPHANKS determined the scale of the two thermometers L and R by comparison with five original thermometers of the A series; and in 1849 and 1850 he compared *l* and *s* with two of the same series. From this time, I conceive, every observation possesses extraordinary value.

In the summer of 1850, seventeen bronze bars and two copper bars were compared with Bronze 12. The excesses of their lengths over that of Bronze 12 were as follows:—

Bronze 2	$-0\cdot0252^r$
6	$+0\cdot0042$
7	$-0\cdot0272$
8	$-0\cdot0018$
18	$-0\cdot0347$
19	$+0\cdot0014$
20	$-0\cdot0146$
21	$-0\cdot0034$
22	$+0\cdot0033$
23	$-0\cdot0054$
24	$+0\cdot0107$
25	$+0\cdot0840$
26	$+0\cdot0379$
27	$-0\cdot0010$
28	$-0\cdot0155$
29	$+0\cdot0364$
30	$+0\cdot0386$
DONKIN'S Copper	$+0\cdot0397$
MAY'S Alloy (32 copper, 1 tin)	$+0\cdot0547$

In the course of these observations, Mr. SHEEPHANKS saw reason for abandoning Bronze 12 as Basis, and adopting Bronze 28 in its stead. He remarked that the length of Bronze 28 ($=$ Bronze 12 $- 0\cdot0155 = 36^{\text{in}}\cdot000048 - 0^{\text{in}}\cdot000056 = 35^{\text{in}}\cdot999992$) was as nearly as possible that of the Imperial Standard, that the bar floated evenly in the quicksilver, and that it was nicely divided. Bronze 12 was not nicely divided, and did not float evenly; and one of its gold dots was much tarnished while the other was quite bright; and the tarnished dot was much disfigured by a mercurial stain. Another consideration, which afterwards led to extensive series of observations, was the following.

A portion of the comparisons of bars abstracted above was made by Mr. W. SIMMS, jun., and a part by Mr. W. ELLIS (of the Royal Observatory). On comparing the results for ten bars, it was found that in every instance Mr. SHEEPSHANKS assigned to these bars a greater length (in reference to Bronze 12) than was given by Mr. W. SIMMS. The mean value of the discordance was about $0^{\text{in}}\cdot000054$; by which, apparently, Mr. SHEEPSHANKS read the length of Bronze 12 shorter than Mr. W. SIMMS read it. Mr. SHEEPSHANKS and Mr. W. ELLIS agreed nearly; and Mr. SHEEPSHANKS and Mr. W. SIMMS agreed nearly when they observed other bars. It was thus that the suspicion of personal equation, in the observation of lines apparently well cut, first arose: and it appeared evident that the divisions of Bronze 12 were peculiarly liable to this personal equation. For this reason, in addition to others mentioned above, Bronze 12 was rejected as Basis. Bronze 28 was adopted in its stead, and was retained as Basis in all the subsequent observations.

SECTION VI.—*Operations of important character to the end of 1853: comparisons of a small number of bars with Bronze 28; investigation of Personal Equation; investigation of the effect of Inside or Outside position of the Bar; investigation of the relative thermometric expansion of Steel, Wrought Iron, Cast Iron, Copper, and Brass, as compared with Bronze; trial and rejection of BAILY'S Apparatus.*

Observations made in the year 1850 had led Mr. SHEEPSHANKS to think it possible that a very small error might depend on the position of the bars as near to or far from the observer. On examining the plans of the comparing apparatus, it will be seen that this could arise in no other way than the following: that the travelling carriage is not exactly in the same position for the observation of the two bars, that the foundation stones will therefore be differently pressed in the two cases, and that therefore there may be (in some way not easily conceived) a strain of the transom bars which carry the microscopes. The first experiments seemed to support this idea; but the more complete experiments of 1852 practically negatived it. The following Table contains the epitome of the observations made at the end of 1850 and the beginning of 1851. Each set of observations is the mean of five comparisons. The excess is in every case increased by $1\cdot0000$, in order to make it always positive. The computations of means and of probable errors were made by Mr. W. ELLIS at the Royal Observatory.

Bars compared with Bronze 28.	Position of Bar Inside or Outside.	Number of sets of observations.	Excess of Bar above Bronze 28 increased by 1 ^r .0000.	Probable Error of one set.	Probable Error of Mean.
Bronze 1	Inside.	4	r. 1.0236	r. 0.004406	r. 0.002203
Bronze 1	Outside.	4	1.0180	0.004088	0.002044
Bronze 2	Inside.	12	0.9986	0.004292	0.001239
Bronze 2	Outside.	12	0.9935	0.004367	0.001261
Bronze 7	Inside.	12	1.0001	0.003359	0.000970
Bronze 7	Outside.	12	0.9977	0.003307	0.000955
Bronze 11	Inside.	8	1.0219	0.008207	0.002902
Bronze 11	Outside.	8	1.0172	0.003534	0.001336
Bronze 12	Inside.	16	1.0137	0.003807	0.000952
Bronze 12	Outside.	16	1.0128	0.004123	0.001031
Bronze 21 (reversed)...	Outside.	16	1.0250	0.003929	0.000982
Bronze 15	Inside.	27	0.9737	0.004888	0.000978
Bronze 15	Outside.	18	0.9678	0.004795	0.001130
Bronze 20	Inside.	12	1.0105	0.003013	0.000870
Bronze 20	Outside.	12	1.0040	0.004775	0.001378

Remarking that the probable error will be the same for the Mean Excess above Bronze 28 and for the Increase of Excess depending upon the Compared Bar being Inside, the results from these observations are the following :—

Name of Bar.	Mean Excess above Bronze 28.	Increase of Excess when compared Bar is Inside.	Probable Error.
Bronze 1	r. 1.0208	r. +0.0028	r. 0.00150
Bronze 2	0.9960	+0.0025	0.00088
Bronze 7	0.9989	+0.0012	0.00068
Bronze 11	1.0195	+0.0023	0.00160
Bronze 12	1.0132	+0.0004	0.00070
Bronze 15	0.9708	+0.0030	0.00075
Bronze 20	1.0072	+0.0032	0.00081

These results undoubtedly support the idea that the bar appears too long when in the Inside position by a quantity not differing much from $0.0022 = 0^{in}.000008$.

Much time was employed, in the latter part of 1851 and the beginning of 1852, in the observations of numerous bars, the results of which will be given hereafter. In many of these observations Mr. W. SIMMS, jun. took a part, and thus there was frequent comparison of the results given by two different observers. In the autumn of 1852, the feeling of insecurity, with regard to personal equation and the influence of the bar's position, pressed so strongly on Mr. SHEEPHANKS, that, after consulting with me, he determined on making an extensive series of observations with the assistance of several observers who were familiar with micrometrical observations, and whose accuracy could not be questioned. The persons who thus aided Mr. SHEEPHANKS were, Mr. HENDERSON and Mr. DUNKIN of the Royal Observatory, Mr. SIMMS, Mr. W. SIMMS, jun., and Mr. WARREN DE LA RUE. The following Table gives the immediate results of the operation. The element exhibited is the apparent excess of each bar above Bronze 28,

except in the last division of the Table, where Bronze 7 is the standard of reference. The "division" is one-hundredth part of a revolution, or $0^{\text{in}}\cdot0000358$. Each "observation" is the mean of three comparisons.

Excess of each Bar above Bronze 28.

Name of Bar.	Observer.	Position of Bronze 28.	Excess when Bronze 28 is outside.	Excess when Bronze 28 is inside.	Number of observations.	Probable Error of Mean.	Symbol for Excess, independent of position but dependent on observer.	
Bronze 10	SHEEPSHANKS.....	Outside.	d.	d.	78	d.	}	
		Inside.	-1.382	-1.131	64	0.0643		} x_2
	HENDERSON	Outside.	-1.830	-1.735	20	0.1396	}	
		Inside.	-1.515	-1.240	20	0.1528		} x_4
	DUNKIN	Outside.	-1.515	-1.240	20	0.1196	}	
		Inside.	-1.240	-1.090	10	0.0940		} x_6
	SIMMS	Outside.	-0.788	-1.669	8	0.1593	}	
		Inside.	-1.669	-1.419	16	0.1138		} x_8
	W. SIMMS, jun. ...	Outside.	-1.656	-2.350	8	0.0849	}	
		Inside.	-2.350	-1.168	8	0.1168		} x_{10}
	DE LA RUE.....	Outside.	-1.575	-1.714	8	0.1696	}	
		Inside.	-1.714	-0.989	14	0.1419		} x_{12}
Bronze 19	SHEEPSHANKS.....	Outside.	+0.213	+0.119	32	0.0989	}	
		Inside.	+0.119	+0.0976	32	0.0976		} x_{14}
	HENDERSON	Outside.	+0.370	-0.430	10	0.1913	}	
		Inside.	-0.430	-0.1456	10	0.1661		} x_{16}
	DUNKIN	Outside.	-0.400	+0.010	10	0.1456	}	
		Inside.	+0.010	+0.1473	10	0.1473		} x_{18}
	SIMMS	Outside.	+0.288	+0.288	8	0.1624	}	
		Inside.	+0.288	+0.0919	8	0.0919		} x_{20}
	W. SIMMS, jun. ...	Outside.	-0.425	-0.400	4	0.1458	}	
		Inside.	-0.400	-0.0634	4	0.0634		} x_{22}
	DE LA RUE.....	Outside.	-0.413	+0.400	8	0.1217	}	
		Inside.	+0.400	+0.1785	8	0.1785		} x_{24}
Bronze 20	SHEEPSHANKS.....	Outside.	+0.514	+0.107	28	0.0996	}	
		Inside.	+0.107	+0.1043	28	0.1043		} x_{26}
	HENDERSON	Outside.	+1.040	-0.040	10	0.2246	}	
		Inside.	-0.040	-0.1365	10	0.2192		} x_{28}
	SIMMS	Outside.	+0.550	+0.363	8	0.1365	}	
		Inside.	+0.363	+0.0908	8	0.0908		} x_{30}
	W. SIMMS, jun. ...	Outside.	+0.750	+0.900	4	0.0773	}	
		Inside.	+0.900	+0.0924	4	0.0924		} x_{32}
	DE LA RUE.....	Outside.	+0.670	+0.895	6	0.0895	}	
		Inside.	+0.895	+0.1947	6	0.1947		} x_{34}
	Bronze 2	SHEEPSHANKS.....	Outside.	-0.495	-0.187	38	0.0862	
			Inside.	-0.187	-0.0892	30	0.0892	} x_{36}
HENDERSON		Outside.	-0.745	-0.805	20	0.1444	}	
		Inside.	-0.805	-0.1281	20	0.1281		} x_{38}
W. SIMMS, jun. ...		Outside.	-1.530	-2.275	4	0.1336	}	
		Inside.	-2.275	-0.0904	4	0.0904		} x_{40}
DE LA RUE.....		Outside.	-0.600	-0.880	4	0.0411	}	
		Inside.	-0.880	-0.3095	4	0.3095		} x_{42}
Bronze 7		SHEEPSHANKS.....	Outside.	+0.506	+1.750	32	0.1133	
			Inside.	+1.750	+0.0881	32	0.0881	} x_{44}
		W. SIMMS, jun. ...	Outside.	-0.500	-0.0985	4	0.0985	
			Inside.	-0.0985	-0.0965	4	0.0965	} x_{46}

TABLE (continued).
Excess above Bronze 7.

Name of Bar.	Observer.	Position of Bronze 7.	Excess when Bronze 7 is outside.	Excess when Bronze 7 is inside.	Number of observations.	Probable Error of Mean.	Symbol for Excess, independent of position but dependent on observer.
Bronze 10	SHEEPSHANKS.....	Outside.	d. -2.711	d.	28	d. 0.1008	} $x_2 - x_{44}$
		Inside.		-2.142	24	0.0973	
	HENDERSON	Outside.	-1.210		10	0.1454	} x_{48}
		Inside.		-1.360	10	0.1744	
	DUNKIN	Outside.	-2.390		10	0.1653	} x_{50}
		Inside.		-1.630	10	0.2988	
	W. SIMMS, jun. ...	Outside.	-0.350		4	0.0506	} $x_{10} - x_{46}$
		Inside.		-1.550	4	0.1728	

It must be remarked that the “probable error” in the Table is the probable chance-error in the mean of observations of the bar under given circumstances, derived in the usual way from the discordances of the observations under those circumstances, and not applying in any degree to a constant error of the observer or a constant error depending on position.

The results were now treated in the following way:—

From examination of Mr. SHEEPSHANKS’s probable errors, it appeared that the probable error of a single “observation” by Mr. SHEEPSHANKS is about 0^d.55. This quantity will be called E.

On comparing the probable errors of the other observers with those of Mr. SHEEPSHANKS, it appeared that their proportions are nearly as follows:—

HENDERSON	:	SHEEPSHANKS	::	9	:	8
DUNKIN	:	SHEEPSHANKS	::	1	:	1
SIMMS	:	SHEEPSHANKS	::	3	:	4
W. SIMMS, jun.	:	SHEEPSHANKS	::	5	:	8
DE LA RUE	:	SHEEPSHANKS	::	6	:	7

It appeared from these that no sensible error would be committed by assuming the observations of all the observers to be equally good, except those of W. SIMMS, jun., one of whose observations is equivalent to two of any other observer. (This estimate agrees entirely with the high opinion of Mr. W. SIMMS’s accuracy which Mr. SHEEPSHANKS had often expressed to me long before this time.) In other words, the probable error of one of Mr. W. SIMMS’s observations will be $\frac{E}{\sqrt{2}}$, that for any other observer being E. And, to make the probable error, of the equation formed for the mean of n observations, equal to E, the equation must be multiplied, for observers in general, by \sqrt{n} : but for Mr. W. SIMMS, jun. it must be multiplied by $\sqrt{2n}$.

Now let x_2 be Mr. SHEEPSHANKS’s value of the excess of Bronze 10 above Bronze 28; y the increase in this value produced by the circumstance of Bronze 28 being Outside

(and consequently $-y$ the increase when Bronze 28 is Inside), y being independent of the Observer and of the Bar.

Then the equations formed from the means of Mr. SHEEPSHANKS'S two sets of comparisons of Bronze 10 with Bronze 28 are,—

$$\begin{aligned}x_2 + y &= -1.382 \\x_2 - y &= -1.131,\end{aligned}$$

these equations being subject to the *probable* errors $\frac{E}{\sqrt{78}}$, $\frac{E}{\sqrt{64}}$.

Or

$$\begin{aligned}\sqrt{78}.x_2 + \sqrt{78}.y &= -\sqrt{78} \times 1.382 \\ \sqrt{64}.x_2 - \sqrt{64}.y &= -\sqrt{64} \times 1.131,\end{aligned}$$

where each equation is subject to the *probable* error E . In this shape, the equations are fit for use in determining the most probable values of x_2 , x_4 , &c., and y .

But we shall afterwards have need to determine the probable errors of the values of x_2 , x_4 , &c., y , so found. For this purpose, it will be most convenient to introduce here the consideration of the *actual* error in each equation. Let then e_1 , e_2 be the *actual* errors in Mr. SHEEPSHANKS'S first and second mean result. Then the following equations are strictly correct:—

$$\begin{aligned}\sqrt{78}.x_2 + \sqrt{78}.y &= -\sqrt{78} \times 1.382 + \sqrt{78}.e_1 \\ \sqrt{64}.x_2 - \sqrt{64}.y &= -\sqrt{64} \times 1.131 + \sqrt{64}.e_2\end{aligned}$$

and similar equations for the other observers and the other bars. The first and last pairs of equations for the comparison of Bronze 10 with Bronze 7 will be—

$$\begin{aligned}\sqrt{28}.x_2 - \sqrt{28}.x_{44} + \sqrt{28}.y &= -\sqrt{28} \times 2.711 + \sqrt{28} \times e_{51} \\ \sqrt{24}.x_2 - \sqrt{24}.x_{44} - \sqrt{24}.y &= -\sqrt{24} \times 2.142 + \sqrt{24} \times e_{52} \\ \sqrt{8}.x_{10} - \sqrt{8}.x_{46} + \sqrt{8}.y &= -\sqrt{8} \times 0.350 + \sqrt{8} \times e_{53} \\ \sqrt{8}.x_{10} - \sqrt{8}.x_{46} - \sqrt{8}.y &= -\sqrt{8} \times 1.550 + \sqrt{8} \times e_{54}.\end{aligned}$$

And from all this assemblage of equations, new equations equal in number to the number of unknown quantities are to be formed according to the rules of the Calculus of Probabilities.

The equations are for the most part very simple, those only which relate to x_2 , x_{10} , x_{44} , x_{46} , and y , presenting any complexity. I shall only give details of the following, as specimens of the form and the treatment of the whole.

By solution of the third and fourth equations, x_4 is found $= -1.78 + \frac{1}{2}e_3 + \frac{1}{2}e_4$. This expression is strictly accurate, but it cannot be used immediately because e_3 and e_4 (the *actual* errors) are not known. But the *probable* values of e_3 and e_4 are $\frac{E}{\sqrt{20}}$, $\frac{E}{\sqrt{20}}$: the *probable* values of $\frac{1}{2}e_3$ and $\frac{1}{2}e_4$ are therefore $\frac{E}{\sqrt{80}}$ and $\frac{E}{\sqrt{80}}$; and therefore (by the theorems of Probabilities) the *probable* value of the combination of these is

$$\sqrt{\left\{\frac{E^2}{80} + \frac{E^2}{80}\right\}} = \frac{E}{\sqrt{40}}.$$

Hence the value of x_4 is -1.78 with a probable error $\frac{E}{\sqrt{40}}$ or $0^d.088$.

The expressions for $x_2, x_{10}, x_{44}, x_{46}$, found from solution of the equations, contain six terms each, multiplying $e_1, e_2, e_{43}, e_{44}, e_{51}, e_{52}$. The expression for y contains fifty-four such terms. In each of these cases, the *probable* value of each term is to be set down separately (not combined with the others by numerical addition or subtraction), the square of each value is to be formed, the sum of the squares is to be taken, and the square root of that sum will be the *probable error* of the quantity under treatment. In this manner, the Results included in the following Table are formed:—

Abstract of results.

y	Apparent increase in measure of referred bar, when the referee is outside		$\left. \begin{matrix} \text{d.} \\ -0.018 \end{matrix} \right\}$	$\left. \begin{matrix} \text{Probable} \\ \text{Error...} \end{matrix} \right\} 0.018.$
Excesses of the Lengths of Bars above Length of Bronze 28.				
	Name of Bar.	Observer.	Excess.	Probable Error.
			d.	d.
x_2	Bronze 10	SHEEPHANKS.....	-1.28	0.042
x_4		HENDERSON	-1.78	.088
x_6		DUNKIN	-1.41	.101
x_8		SIMMS	-1.39	.079
x_{10}		W. SIMMS, jun.	-1.83	.074
x_{12}		DE LA RUE.....	-1.66	.117
x_{14}	Bronze 19	SHEEPHANKS.....	+0.17	.069
x_{16}		HENDERSON	-0.03	.123
x_{18}		DUNKIN	-0.20	.123
x_{20}		SIMMS	+0.29	.097
x_{22}		W. SIMMS, jun.	-0.41	.138
x_{24}		DE LA RUE.....	-0.01	.138
x_{26}	Bronze 20	SHEEPHANKS.....	+0.31	.074
x_{28}		HENDERSON	+0.50	.123
x_{30}		SIMMS	+0.46	.097
x_{32}		W. SIMMS, jun.	+0.83	.138
x_{34}		DE LA RUE.....	+0.63	.159
x_{36}	Bronze 2	SHEEPHANKS.....	-0.36	.067
x_{38}		HENDERSON	-0.78	.087
x_{40}		W. SIMMS, jun.	-1.90	.138
x_{42}		DE LA RUE.....	-0.74	.195
x_{44}	Bronze 7	SHEEPHANKS.....	+1.15	.055
x_{46}		W. SIMMS, jun.	-0.72	.104
Excess of the Length of Bar above Length of Bronze 7.				
x_{48}	Bronze 10	HENDERSON	-1.29	.123
x_{50}		DUNKIN	-2.01	.123
Excess of the Length of Bar above Length of Bronze 28 through the intermediation of Bronze 10.				
$x_4 - x_{48}$	Bronze 7	HENDERSON	-0.49	.150
$x_6 - x_{50}$		DUNKIN	+0.60	.159

It seems difficult here to resist the conclusion that there is a very sensible personal equation. The difference between the results of different observers for the same bar does in every instance greatly exceed any amount of discordance which could be inferred as probable from the combination of probable errors. It is to be particularly remarked that (so far as I can trace in the observations) all the observations of any one bar Inside were taken by all the observers without disturbing the bar, and then all the observations of the same bar Outside were taken by all the observers without disturbing the bar, or *vice versa*.

On comparing the value found for y with its probable error, it does not appear certain that there is any difference between results with Bar Inside and Bar Outside.

The best way of combining the results of the different observers, with due attention to the circumstance that the chance-error of each observer's result is far below their constant difference, appears to be, to take the simple arithmetical mean. Thus we obtain—

$$\begin{aligned} \text{Bronze 10} &= \text{Bronze 28} - 1.56 \\ \text{Bronze 19} &= \text{Bronze 28} - 0.03 \\ \text{Bronze 20} &= \text{Bronze 28} + 0.55 \\ \text{Bronze 2} &= \text{Bronze 28} - 0.95 \\ \text{Bronze 7} &= \text{Bronze 28} + 0.14 \end{aligned}$$

In the year 1853, nearly the whole time from March to September was occupied with experiments on the relative expansions of bars of several metals; Bronze 28 being in all cases the standard of reference. The principal part of the observations was made by Mr. SHEEPHANKS: some however were made by Mr. W. SIMMS, jun. I am aware that these observations were made with very great care, although I cannot state every particular of the cautions which were employed. The temperature was given by the temperature of the water in the external trough; and I find that, when the temperature had been altered by pouring in hot water, &c., no observations were made until six or more hours after the alteration. In some cases, the trough was wrapped in blankets during the night. The readings of L and R were converted into degrees of FAHRENHEIT by the Table made from the last comparisons of these thermometers. The observations were subsequently reduced by Mr. W. ELLIS at the Royal Observatory.

Each "observation," as before, is the mean of three comparisons; and one revolution = $0^{\text{in}}.003587$.

It will be sufficient to exhibit, as a specimen, the reduction of the observations of one bar; and for that purpose I will take Swedish Iron B.

Excess of Swedish Iron B above Bronze 28.

$$\begin{aligned} \text{Sum of excesses in 24 observations at mean temperature } 40.972 &= + 17.0053 \\ \text{Sum of excesses in 28 observations at mean temperature } 59.313 &= + 2.6529 \\ \text{Sum of excesses in 16 observations at mean temperature } 63.215 &= - 0.5738 \\ \text{Sum of excesses in 16 observations at mean temperature } 68.143 &= - 3.2412 \end{aligned}$$

Let x be the excess of Swedish B above Bronze 28 at the temperature 0° ; y the relative expansion for 1° . Then the first line gives the equation

$$24 \times x + 983.33 \times y = +17.0053,$$

and so for the others. These equations, assumed to be of equal value, were treated by the method of least squares, and the result was

$$x = +2.081441$$

$$y = -0.03350280.$$

On substituting these values in the four equations, the residual errors are

$$-0.0050, \quad +0.0127, \quad +0.0092, \quad -0.0168,$$

which prove that there are no important errors of observation or reduction.

To find the excess of Swedish Iron B at temperature 62° , we must form $x + y \times 62$. Its value is $+0.004267$.

And, as the relative expansion is -0.0335 or -0.000120 : if to this we apply the absolute expansion of Bronze $+0.000341$ (as found above), the absolute expansion of Swedish Iron B for 1° of FAHRENHEIT is $+0.000221$. This applies to the length 36 inches.

In all the other instances, the range of temperature is almost exactly the same as for Swedish Iron B, but the number of observations is greater. For Cast Steel B the number is 148.

The following is an Abstract of Results:—

Name of Bar.	Excess above Bronze 28 at 62° FAHRENHEIT.	Relative expansion of 36 inches for 1° FAHRENHEIT.
	r.	r.
Cast Steel B	-0.006565	-0.03730370
Low Moor B	$+0.005113$	-0.03356648
Swedish B	$+0.004267$	-0.03350280
Cast Iron C	-0.018638	-0.03979733
Brass 2	$+0.082740$	$+0.00072975$
DONKIN'S Copper	$+0.011634$	-0.00743411

About 1853, October 26, Mr. SHEEPSHANKS introduced the use of the "block-and-stirrup" mounting, and I believe that after this time the system of floating the bars in quicksilver was rarely or never used.

Between 1853, August 20, and December 24, Mr. SHEEPSHANKS made numerous comparisons of several bars, by the use of BAILY'S Apparatus (the comparing apparatus of the Royal Astronomical Society). He was however much dissatisfied with the results, and never reduced them to the state of Abstracts. In a letter to myself, dated 1854, Jan. 2, Mr. SHEEPSHANKS says, "There is a clear difference in the comparisons depending on the position of the bars: the inside bar is always the longest. But this difference varies most lawlessly, from 3^d to 10^d ," and then gives the means of comparisons on four days, each mean being derived from 18 observations, as follows:—

Brass 2 farthest—Kew Bar nearest	-1.93	-0.97	-2.42	-4.02
Brass 2 nearest—Kew Bar farthest	$+9.20$	$+10.05$	$+7.35$	$+4.10$

SECTION VII.—*Comparisons of numerous bars from 1851 to 1855; suspicion of change in Bronze 28; removal of the suspicion; close of the operations for defining the Yard by line-measure.*

I have interrupted the chronological order, for the sake of bringing together in the last Section the observations of fundamental character, and in the present Section the mere determinations of the length of numerous bars.

In a former Section I gave the differences found by Mr. SHEEPHANKS between Bronze 12 and the following bars (among others)—

Bronze	6
	8
	18
	21
	22
	23
	24
	25
	26
	27
	29
and also Bronze	28

These bars were subsequently compared with Bronze 28, and they therefore afforded very good means of comparing the two fundamental bars Bronze 12 and Bronze 28. Their excesses above Bronze 28 were as follows:—

d.	d.	} and direct comparisons had given for Bronze 12 + 1 ^d .55.
Bronze 6 + 2.90	Bronze 24 + 3.12	
8 + 1.73	25 + 4.77	
18 - 3.32	26 + 4.47	
21 + 2.22	27 + 1.84	
22 + 2.62	29 + 3.71	
23 + 3.12		

Combining these differences with the differences of the same bars from Bronze 12, inferring from each the value of Bronze 12 with respect to Bronze 28, and taking the mean of all, with fivefold weight for the direct comparison,

$$\text{Bronze 12} = \text{Bronze 28} + 1^{\text{d}}.84.$$

This value was used for connecting the inferred lengths (from comparison with Bronze 12) with the inferred lengths (from comparison with Bronze 28): then, in all cases where both bases had been used, a general mean was taken.

Thus by comparison, sometimes with one base, sometimes with two, the following differences from Bronze 28 were determined. For convenience of reference, I have included in the same Table the differences determined in the last Section.

Bronze Bars.

	d.		d.
Bronze 1	+2·08	Bronze 23	+2·21
2	-0·95	24	+3·02
3	-2·28	25 (redivided)	+0·25
4	+4·63	26	+5·05
5	+0·52	27	+1·79
6	+2·58	28	(0·00)
7	+0·14	29	+4·60
8	+1·70	30	+3·24
9	+7·14	31	-0·34
10	-1·56	32	-0·36
11	+1·96	33	+0·71
12	+1·84	34	-0·25
13	+1·35	35	+0·47
14	+3·85	36	-0·75
15	-2·92	37	-0·62
16	+0·56	38	-1·33
17	-1·30	39	+1·21
18	-2·48	40	+0·07
19	-0·03	BAILY'S A	-3·50
20	+0·55	B	+3·09
21	+1·86	C	+4·05
22	+2·40	D	+3·01

Brass Bars.

(Brass 2 is a fundamental bar, whose value was obtained in a preceding Section. The Kew Bar was compared with Brass 2 and Bronze 28: all the others with Bronze 28 only. The Flat Brass Scale appears to have been compared on BAILY'S apparatus: all the others, I believe, with Mr. SHEEPHANKS'S apparatus.)

Brass 1	d.	Royal Astronomical Society's Tubular	d.
2	+ 0·07		+11·67
Flat Brass Scale.	+ 8·27	Danish Tubular	+12·01
Kew Bar	- 0·12	SIMMS'S Tubular 4	+13·88
New Tubular Scale	+ 1·54	BAILY'S Tubular 5	+19·42
	-10·27		

Copper Bars.

(DONKIN'S is in the last Section. MAUDSLAYS' and MAY'S were compared with Bronze 12.)

DONKIN'S Copper	d.
MAUDSLAYS' Copper	+1·16
MAY'S Alloy	+1·60
	+4·15

Iron and Steel Bars.

(Swedish B, Low Moor B, Cast Iron C, and Cast Steel B, are in the last Section.)

Swedish A, by comparison with	{ Bronze 12 Bronze 28 }	d. -9.50
Swedish B.	+0.43
Swedish C, by comparison with	Low Moor B	+1.43
Low Moor A, by comparison with	{ Bronze 28 Low Moor B }	-3.56
Low Moor B.	+0.51
Low Moor C, by comparison with	Low Moor B	+2.16
Low Moor D, by comparison with	Low Moor B	+1.28
Cast Iron A, by comparison with	{ Bronze 12 Low Moor B }	-3.08
Cast Iron B, by comparison with	Low Moor B	-4.96
Cast Iron C.	-1.86
Cast Iron D, by comparison with	{ Bronze 28 Low Moor B }	-3.52
Cast Steel A, by comparison with	Low Moor B	-1.28
Cast Steel B.	-0.66
Cast Steel C, by comparison with	Low Moor B	-2.70
Cast Steel D, by comparison with	{ Swedish B Low Moor B Cast Iron C Cast Steel B }	-3.61

Bars and scales which had formerly been compared with the Imperial Standard.

Ordnance 1 A, by comparison with	{	Bronze 12	- 9.12
		Brass 2	- 7.63
		Swedish A	-11.03
		Low Moor A	-10.19
Ordnance 2 A, by comparison with	{	Low Moor B	- 8.57
		Bronze 12	- 3.87
		Brass 2	+ 1.14
KATER'S Royal Society Standard, by comparison with	{	Swedish A	-12.31
		Low Moor A	- 4.58
		Low Moor B	- 4.74
SHUCKBURGH'S Scale, 0-36, by comparison with . .	{	Bronze 28	-20.78
		Bronze 12	-15.11
		Brass 2	-14.61
SHUCKBURGH'S Scale, 10-46, by comparison with . .	{	Brass 2	+ 8.43
		Brass 1	+ 4.09
		Brass 2	+ 2.29

Ancient Bars.

	d.
Henry VII., by comparison with Brass 2	-1041·34
Elizabeth, by comparison with Brass 2	- 285·93
Excheq., by comparison with Brass 2	- 155·01
Tower, by comparison with Brass 2	+ 53·27
Anonymous, by comparison with Brass 2	+ 49·43

Mr. SHEEPHANKS usually investigated the “probable error” of every result. It has appeared to me unnecessary to record them here. They may be understood to range, in general, a little above or a little below 0^d·1, when line-divisions on firm bars were compared.

It will be convenient, in estimating the import of the various numbers given above, that the reader should remember the following values:—

1^d·00 = 0ⁱⁿ·000036 nearly = one-millionth part of the yard-measure.

1^d·00 = Expansion of 36 inches of Bronze for 0°·10 FAHRENHEIT.

= Expansion of 36 inches of Iron for 0°·17 FAHRENHEIT.

For accurate reduction, the following thermometric expansions of 36 inches for 1° FAHRENHEIT are to be used:—

	d.	in.
Bronze	9·507	= 0·000341
Brass	9·580	= 0·000344
Copper	8·764	= 0·000314
Wrought Iron	6·153	= 0·000220
Cast Iron	5·527	= 0·000198
Cast Steel	5·777	= 0·000207

In the statements of results of comparison, it is always supposed that both bars are at the temperature 62° FAHRENHEIT, unless a temperature is stated.

Between 1855, March 15 and April 3, Mr. SHEEPHANKS made three careful series of observations for ascertaining the effect of flexure on the measure of a bar. Bronze D was compared with Bronze 28, the circumstances of Bronze D being varied as follows:— 1st. Bronze D was supported on block-and-stirrup, the points of support being those indicated by theory: 2nd. Bronze D was supported in the middle, a trifling preponderance being given to one end in order to prevent oscillation: 3rd. Bronze D was supported by block-and-stirrup at the extreme ends. The position of Bronze 28 was not varied. The results for the excess of Bronze D above Bronze 28 were—

	d.
1st series, by 96 observations	+ 3·01
2nd series, by 72 observations	+ 3·03
3rd series, by 72 observations	+ 3·06

It is sufficiently clear that the effect of flexure is insensible.

I proceed now to allude to a discordance which was a source of great anxiety to Mr. SHEEPSHANKS.

In April 1855, Mr. SHEEPSHANKS was engaged in measuring the bar Cast Steel D. By comparisons with four iron bars (as is stated in the Table above), whose results agreed very closely, the excess of Cast Steel D above Bronze 28 was found to be $-3^{\text{d}}.61$. But a direct comparison of Cast Steel D with Bronze 28, immediately preceding, had given $-0^{\text{d}}.46$. This comparison was made at the temperature $45^{\circ}.54$, or $16^{\circ}.46$ below the standard temperature. A trifling error of expansion might account for part of the discordance; and ordinary errors of observation might account for part. But in the opinion of Mr. SHEEPSHANKS, though the whole discordance scarcely exceeded the effect of the thermometric expansion of Bronze 28 for $0^{\circ}.3$ FAHRENHEIT, it was impossible so to explain away the whole or a large part of it; and he was convinced that Bronze 28 had sensibly shortened. And so deeply and so painfully was this impression fixed in his mind, that he actually contemplated the rejection of all the results which had cost so many years of labour, and the commencing the work *de novo*.

The first conjecture on the possible cause of the apparent change was, that Bronze 28 while covered with gold-beater's skin and cement (as in the earlier comparisons) might have been so far constrained by that covering that it could not shrink down to its natural length; but that in the last comparisons with Cast Steel D, when that covering had been removed, it had contracted itself. In order to test this, Mr. SHEEPSHANKS immediately made measures of Bronze 12, Bronze 29, Bronze A, and Bronze B, whose coverings had not been removed; then he had the covering removed, and repeated the measures. The following is a comparison of these measures:—

Excess above Bronze 28.		
		d.
Bronze 12, before cleaning,	1855 April 26	+4.50
after cleaning,	May 1	+4.77
Bronze 29, before cleaning,	May 5	+3.70
after cleaning,	May 8	+4.28
Bronze A, before cleaning,	May 9	-2.36
after cleaning,	May 11	-2.46
	June 5 to 9	-2.51
Bronze B, before cleaning,	May 10	+4.15
after cleaning,	May 12	+4.51
	May 31	+3.57
	June 1 and 2	+4.59

It seems sufficiently evident that nothing depends on the covering.

Numerous observations were then made, partly by Mr. SHEEPSHANKS himself and partly by a young assistant, on twenty-seven bars (including the four just mentioned) which had been previously well compared with Bronze 28. The result is exhibited in the following Table:—

Excess above Bronze 28.

Bar.	Old measure.	New measure.	Bar.	Old measure.	New measure.
Bronze 12	d. +1.84	{ +4.50 +4.77	Bronze 14	d. +3.85	{ +3.69 +2.98
Bronze 39	+1.21	+0.45			+3.46
Bronze 15	-2.92	-1.63	Bronze 23	+2.21	+2.50
Bronze 11	+1.96	{ +2.58 +2.66			+1.76
Bronze 30	+3.24	+3.01	Bronze 21	+1.86	+2.87
Bronze 29	+4.60	{ +3.70 +4.28			+4.51
Bronze 1	+2.08	+4.05	Bronze 9	+7.64	+4.80
Bronze A	-3.50	{ -2.36 -2.46	Bronze 22	+2.40	+8.06
		-2.51	Bronze 3	-2.28	+3.40
Bronze B	+3.09	{ +4.15 +4.51	Bronze 6	+2.58	-1.56
		+3.57	Bronze 26	+5.05	+0.04
Bronze 16	+0.56	+4.59	Bronze 27	+1.79	+3.89
Bronze 18	-2.48	-0.65			+4.75
		-1.10	Bronze 25	+0.25	+1.31
Bronze 5	+0.52	{ +0.17 -0.20			+0.91
		+0.58	Bronze 13	+1.35	+0.10
Bronze 4	+4.63	+4.83			-1.11
Bronze 8	+1.70	+2.75	Bronze 24	+3.02	+2.87
		-0.07			-0.04
Bronze 17	-1.30	-0.92			+2.25
		-1.28			+1.90
		-1.84			+4.96
					+2.88
					+4.98
					+3.96

The order in which I have placed the bars is the same as the chronological order of the first of the New Observations on each bar. On examining them it will be found,—First, that there is no evidence whatever of a general preponderance of excess from the New Measures above excess from the Old Measures; the signs + and - being intermixed, in the differences, in all possible ways; and the mean of the whole being less than 0^d.50. Secondly, that the only instance which fairly supports the conclusion deduced from Cast Steel D is the first of all, namely, Bronze 12. Cast Steel D was compared on April 13, 14, and 16; Bronze 12 on April 26, 27, 28, and May 1; Bronze 39 (the next) on April 30. The conclusion, I think, is inevitable, that Bronze 28 really was shortened at the beginning of April; that it recovered its exact length before April 30; but that this recovery took place with some fluctuations, so that on May 1 it was subject nearly to the same error as before. Bronze 21, observed on June 26, exhibits a similar discordance. What circumstances can have produced these changes, or how far the later fluctuations are apparent rather than real, I am wholly unable to conjecture.

I know not whether Mr. SHEEPSHANKS intended to continue this series of comparisons. Those which are given are clearly sufficient to establish the general trustworthiness of all the measures; and Mr. SHEEPSHANKS, as they advanced, had expressed himself in a great measure satisfied.

I have now to give the melancholy termination of this part of the work.

To 1855, July 14 inclusive, the whole of Mr. SHEEPSHANKS'S observations, so far as I can discover, are transferred from the Memorandum Book to the Reduction Papers, and the means are taken. The final series of observations are the last two sets of comparisons of Bronze 17 with Bronze 28. After the observations of July 14, the following note is placed in the Memorandum Book:—

“1855, July 25. I went to Reading on the 14th, and felt my head so deranged that I stayed there till Friday 20th, when I came up to arrange my apparatus. I did only a little in the latter affair, but I left pretty full instructions for W. S. [WILLIAM SIMMS, jun.], who has, I believe, carried them out with his usual skill. I told him that the microscopes had not the same scale, and that D would require to be set a trifle lower. He preferred taking a bit off A, and so get them nearer to the same length and to have the focus of distinct vision in the same horizontal line. But it will alter the scale of A.”

Then follow a few observations (one page only, with a few subtractions on the next page) which I am not able to interpret with certainty. They are not dated.

Mr. SHEEPSHANKS had returned to London, on some day in the week commencing with Monday, July 23, and had, as I conceive, made some trials of the apparatus, which were registered (for the moment only) in the unintelligible entries to which I have alluded. I understand that he was engaged on the apparatus on Saturday, July 28; but several persons had remarked that he was evidently in great distress. On the afternoon of that day he went to his residence at Reading, carrying with him a large travelling-bag full of papers relating to the standards. In the afternoon of Sunday, July 29, while sitting in family society, he fell speechless from his chair, struck with apoplexy, and expired on August 4.

Thus died—almost in the scene of his labours, and with his thoughts still intent on them—a man whose equal, in talent and perseverance, in disinterestedness, in love of justice and truth, I have scarcely known. He had however brought to a satisfactory termination the great division of the Standard-work which best suited his taste, having well overcome the last of the difficulties which had presented themselves, and leaving the work in such a state that not a single additional comparison of line-measures was required. All that was necessary was, to collect and arrange the papers, to complete some few means and abstracts which he had been unable to finish, and to draw up such an account as I have attempted here. The formation of thermometers was left in an imperfect condition, but (under pressing occupations) I have not felt myself called upon to finish them. The essential object was, to construct accurate copies of the National Standard, which rests upon an arbitrary basis; this work could be done by no persons except those who had daily access to the National Standard. The basis of thermometers is natural, and they can be constructed by one physicist or workman as well as by another. And at the present time, it is very much easier to procure in commerce thermometers of well-established accuracy than it was when Mr. SHEEPSHANKS commenced his labours.

SECTION VIII.—*Formation of End-measure Bars.*

The form given to the end-bars depended in some degree upon the process adopted for comparing end-measure bars with line-measure bars, which originated, I believe, in a suggestion from myself. Suppose that we have *two* end-bars, each nearly equal in length (as measured between its extreme ends) to the length of the line-bars (as measured from line to line). Suppose also that each of the end-bars has a well sunk to the middle of its depth, with a transverse line cut upon a pin (as in the line-measures); the line being not necessarily at the middle of the length of the bar, though it is essential that its distance from the centre of the bar's length be nearly the same in both end-bars. As, generally, one segment of the bar, from the transverse line to the end, will be longer than the other segment, let the longer segment be denoted by $+$ and the shorter by $-$. And suppose that the two bars are placed end to end, the $+$ end of one being opposed to the $-$ end of the other, as shown in Figure 11. The distance between their transverse lines will evidently be the sum of the $+$ segment of the first bar and the $-$ segment of the second bar; and the conditions that I have stated, as to the similar division of the lengths of the two bars, will make that sum so nearly equal to the length of the line-measure, that the difference may be measured by the micrometer-apparatus. Then interchanging the positions of the end-bars, so that their other ends shall be in contact, the distance under observation will be the sum of the $-$ segment of the first bar and the $+$ segment of the second bar. Adding together the two measured distances, we have a comparison of the sum of the two end-bars with double the length of the line-bar.

In order to make this determination available, it is necessary further to determine the difference between the whole lengths of the two end-bars. A felicitous suggestion by Mr. W. SIMMS, jun. gave the means of doing this. Mr. W. SIMMS's proposal was, to apply the process above described to *three* end-bars, determining the measure of the sum of each pair of end-bars in reference to double the length of the line-bar; then there are given three equations to find three unknown quantities. The length of each of the three end-bars is thus found without difficulty.

The general principle of determining the lengths of the end-bars by the contact of their ends (without the use of supplementary pieces, such as had been employed in all previous determinations) being adopted, it was important to decide on the form of those ends. In the opinion of the Committee, the use of plane ends could not be sanctioned. One difficulty attending them is, the uncertainty as to the removal of particles of dust, &c. from every part, and the certainty that if any such particles remain they will disturb the measure of the bar; while at the same time the act of pressing two bars together, either with or without a slight movement, does not tend to remove the particles. Another difficulty is that, even though we were assured that the ends are perfectly clean, yet we cannot be assured that the bars, when laid in a horizontal position end-to-end, will touch in the whole breadth of their ends; inasmuch as, if the position of one of the bars is slightly erroneous in azimuth, or slightly erroneous in inclination to the horizon,

no force which it is practicable to apply in the mounting of the bars would tend to correct the error. The only way which seems practicable is, to place the bars in the vertical position, one bar standing freely upon the end of the other; but this requires a rather inconvenient arrangement of the microscopes.

These errors and inconveniences are entirely avoided by giving to the ends the form of a spherical surface whose centre is the centre of the division-line at the middle of the bar's length. There is a tendency to thrust away particles of dust from the point of contact; and a small error in the elevation, or inclination, or azimuthal position, of either bar, produces no error on the distance between the centres of the division-lines of the two bars.

Accordingly, about the beginning of 1854, Mr. SHEEPSHANKS arranged an apparatus for grinding the ends of end-bars. The bar was grasped by its middle, in a cramp which turned in jimbals or universal-joint; and a plane surface carrying a grinding powder was placed at the proper distance. The operation requires no explanation.

It was then necessary to decide on the substance which should be used for the hard ends of the bars. The properties required were, hardness, toughness, and susceptibility of polish. After several trials, it was found best to use a very slightly conical plug, of either agate or hardened steel (the reason for subsequently abandoning the hardened steel will be given hereafter), and to fix the plug in the corresponding very slightly conical hole at the end of the bar, by fitting it in when the bar was somewhat heated (below the boiling-point of water) and allowing the metal of the bar to shrink upon it. Then the metal and the plug were ground at the same time, so as to make a flush joint. It was found best to give any final reduction of length by a polishing-touch of the hand.

Mr. SHEEPSHANKS had commenced the preparation of some end-bars; but this process, in which a bar if too much shortened is injured beyond the possibility of restoration except by inserting a new plug, is very tedious. This was more particularly felt, when the grinding and polishing were effected in Mr. SIMMS's workshop, and the optical test was applied at Somerset House. No efficient progress was therefore made, up to the time of Mr. SHEEPSHANKS's decease. On then revising the condition of the work, and after having consulted with Professor MILLER, I requested Mr. SIMMS to undertake the whole operation of testing and adjusting the bars in his own workshops, and finally of making the definitive comparisons with Bronze 28 on Mr. SHEEPSHANKS's apparatus at Somerset House.

The bars first tried were those prepared by Mr. SHEEPSHANKS, some having agate ends, some having ends of hardened steel. It happened that an end of agate and an end of hardened steel were left in contact for about a day, when it was found that the distance between their division-lines had increased about $\frac{1}{1000}$ th of an inch. Upon examining the end of the steel plug, it was found that the proper point of contact and a disk about $\frac{1}{20}$ th of an inch in diameter was clean; but an annulus surrounding it, of the breadth perhaps of $\frac{1}{10}$ th of an inch, was thickly rusted; and that the rust had acted like a wedge, forcing the bars asunder in opposition to a spring-pressure of about 3 lbs. It

would seem that the steel and agate formed a galvanic combination, like zinc and copper; and that the air, or its moisture, then acted energetically upon the steel. The steel plugs were then withdrawn, and agate plugs were substituted, and no further difficulty was experienced.

In the definitive comparisons at Somerset House, the bars were always supported on lever-frames, in the manner shown in figures 11 and 12.

The following is an abstract of the comparisons:—

Bronze End-bars called No. 45, No. 69, and No. 74 compared with Bronze 28. Observations by Mr. W. SIMMS, jun. and Mr. JAMES SIMMS. One division = $0^{\text{in}} \cdot 0000359$.

No. 69 with No. 74, by 48 observations, exceed Bronze 28 by $-13 \cdot 66^{\text{d}}$

No. 74 with No. 69, by 48 observations, exceed Bronze 28 by $+17 \cdot 67$

Therefore No. 74 + No. 69 exceed $2 \times$ Bronze 28 by $+4^{\text{d}} \cdot 01$.

No. 69 with No. 45, by 48 observations, exceed Bronze 28 by $-1 \cdot 43$

No. 45 with No. 69, by 48 observations, exceed Bronze 28 by $+2 \cdot 79$

Therefore No. 69 + No. 45 exceed $2 \times$ Bronze 28 by $+1^{\text{d}} \cdot 36$.

No. 45 with No. 74, by 48 observations, exceed Bronze 28 by $-14 \cdot 28$

No. 74 with No. 45, by 48 observations, exceed Bronze 28 by $+13 \cdot 37$

Therefore No. 45 + No. 74 exceed $2 \times$ Bronze 28 by $-0^{\text{d}} \cdot 91$.

Solving the three equations,

Bronze End-bar No. 45 = Line-measure Bronze 28 $-1 \cdot 78^{\text{d}}$

Bronze End-bar No. 69 = Line-measure Bronze 28 $+3 \cdot 14$

Bronze End-bar No. 74 = Line-measure Bronze 28 $+0 \cdot 87$

End-bars called Steel 72, Steel 73, and Iron 70 compared with Line-measure Steel B.

Steel 73 with Steel 72, by 48 observations, exceed Steel B by $+5 \cdot 31^{\text{d}}$

Steel 72 with Steel 73, by 48 observations, exceed Steel B by $-3 \cdot 92$

Therefore Steel 73 + Steel 72 exceed $2 \times$ Steel B by $+1^{\text{d}} \cdot 39$.

In these comparisons, the temperature is unimportant.

Iron 70 with Steel 72, by 48 observations, exceed Steel B by $-12 \cdot 71$

Steel 72 with Iron 70, by 48 observations, exceed Steel B by $+9 \cdot 10$

Therefore Iron 70 + Steel 72 exceed $2 \times$ Steel B by $-3^{\text{d}} \cdot 61$.

These comparisons were made at mean temperature $50^{\circ} \cdot 48$. But the expansion of Iron (36 inches) for 1° FAHRENHEIT = $6^{\text{d}} \cdot 153$; that of Steel = $5^{\text{d}} \cdot 777$: the relative expansion of Iron therefore = $+0^{\text{d}} \cdot 376$; or for $11^{\circ} \cdot 52$ FAHRENHEIT = $+4^{\text{d}} \cdot 35$. Hence at

temperature 62° FAHRENHEIT,

Iron 70 + Steel 72 exceed 2 × Steel B by +0^d.74.

Steel 73 ⁺ with Iron 70, by 48 observations, exceed Steel B by +13^d.97

Iron 70 ⁺ with Steel 73, by 48 observations, exceed Steel B by -16.73

Therefore Steel 73 + Iron 70 exceed 2 × Steel B by -2^d.76.

These comparisons were made at mean temperature 51°·69. The correction for expansion is +3^d.89. Hence at 62° FAHRENHEIT,

Steel 73 + Iron 70 exceed 2 × Steel B by +1^d.13.

Solving the three equations,

Iron End-bar No. 70 = Line-measure Steel B + 0^d.24

Steel End-bar No. 72 = Line-measure Steel B + 0^d.50

Steel End-bar No. 73 = Line-measure Steel B + 0^d.89

But Line-measure Steel B = Bronze 28 - 0^d.66.

Hence, finally,

Iron End-bar No. 70 = Line-measure Bronze 28 - 0^d.42

Iron End-bar No. 72 = Line-measure Bronze 28 - 0^d.16

Iron End-bar No. 73 = Line-measure Bronze 28 + 0^d.23

For obtaining the length of another Iron End-bar No. 71, the End-bars Iron No. 70 and Iron 71 were compared with the Iron line-measure Low Moor B:

Iron 70 ⁺ with Iron 71, by 48 observations, exceed Low Moor B by -13^d.48

Iron 71 ⁺ with Iron 70, by 48 observations, exceed Low Moor B by +11^d.95

Therefore Iron 70 + Iron 71 exceed 2 × Low Moor B by -1^d.53.

But Low Moor B = Bronze 28 + 0^d.51: and Iron 70 = Bronze 28 - 0^d.42. Hence Iron 71 = Bronze 28 + 1^d.02 + 0^d.42 - 1^d.53. Or

Iron End-bar No. 71 = Line-measure Bronze 28 - 0^d.09.

These are all the End-bars whose lengths were independently determined.

SECTION IX.—*Closing proceedings of Official Character; Extracts from the Final Report of the Commission; Extracts from the Act of Parliament legalizing the New Standard; standard temperatures for the compared bars; disposal of the bars.*

The very elaborate comparison of Bars described in Section VI., and the careful comparison of other Bars in Section VII., gave the Committee ample choice of Bars for National Standards. At the suggestion of Mr. SHEEPHANKS, the selection was in some measure guided, not only by the near approach in length to the presumed length of the Lost Imperial Standard, but also by the clearness of the division and the general good workmanship.

It will be remarked that no one of the Bars compared agrees *precisely* in length with

the Imperial Standard. But this disagreement is a mere exhibition of figures, in regard to a matter to which the accuracy of those figures is totally inapplicable. The Old Imperial Standard was so badly defined that its length was truly indeterminate, to an extent infinitely beyond the disagreement to which I allude. There is also a small range of uncertainty in the modern determinations, but very far below that in the references to the Old Standard. With all these considerations before them, the Committee felt themselves justified in considering Bronze 19 and Bronze 28 as exact copies of the Old Standard, and in recommending the adoption of Bronze 19 as the New Parliamentary Standard.

It was now found convenient to distinguish the Bars by a new order of numeration, commencing with No. 1 for the Parliamentary Standard. It was also thought convenient to distinguish the lengths of the Bars, not by stating their linear difference from Bronze 19 or Bronze 28 at the common temperature 62°·00 FAHRENHEIT, but by stating the temperature at which the length of each bar is the same as the length of Bronze 19 at 62° FAHRENHEIT. Some of these arrangements were not completely carried out until after the death of Mr. SHEEPHANKS.

The Final Report of the Committee, addressed to the Lords Commissioners of Her Majesty's Treasury, was signed on 1854, March 28. It will be better to give here a few Extracts from the Report than to state in detail the later proceedings of the Committee.

Extracts from the "Report of the Commissioners appointed to superintend the Construction of New Parliamentary Standards of Length and Weight."

"2. By the authority of the Lords Commissioners of the Treasury, and by the courtesy of scientific societies, the following standard length-scales were placed at our service:—

Length-scales which had been compared with the lost Imperial Yard Standard.

Two 3-foot Iron Bars belonging to the Department of the Ordnance Survey.

SHUCKBURGH'S Scale, in the possession of the Royal Society.

The Brass Scale of the Royal Society, No. 46.

The Brass Tubular Scale of the Royal Astronomical Society.

"3. We have also had access to other length-scales, which were not available for absolute restoration of the values of the lost standards, but which we have thought it desirable to examine, as illustrating the construction of the lost standards. Such are,—

The ruined Imperial Yard Standard (in the custody of the Right Honourable the Speaker of the House of Commons).

TROUGHTON'S 5-foot scale (presented by W. SIMMS, Esq., and now preserved at the Royal Observatory, Greenwich).

RAMSDEN'S 20-foot bar, and ROY'S 3-foot bar (purchased by the Committee, and now deposited at the Royal Observatory, Greenwich).

Construction of the Standard of Length.

“4. In regard to the linear measure to be represented by the Standard of Length, we see no reason to depart from the decision in the Report of 1841, December 21, Article 19, to adopt the length of One Yard.

“5. The first important question which was left open to us by Article 20 of the same Report, was whether the measure of length should be defined by the whole length of a bar, or by the distance between two points or lines marked on it; and to this question we gave our early and careful consideration.

“6. The most celebrated of the standards constructed in modern times is the new Prussian Standard, made by the late astronomer, BESSEL. In this standard, the whole length of the bar is adopted as the measure of length. The reasons which induced BESSEL to substitute a standard of this construction (or standard *à bouts*) for the standard in which the measure is defined by the distance between points or lines upon its surface (or standard *à traits*), which was the principle of construction of the former Prussian Standard, are explained in page 7 of the Introduction to BESSEL'S Account of the construction of the new Prussian Standard*. The first of these reasons is, that if a flexible bar be supported on two points, the extreme length of the bar from the centre of one end to the centre of the other end is not sensibly altered by its flexure, but the distance between two points or lines upon the upper surface may be considerably altered. BESSEL has himself, however, remarked, that this objection to line-measure is removed if the lines be engraved on surfaces which are depressed to the middle of the thickness of the bar (a principle long since employed in English standard bars); and, moreover, the tendency to alter the apparent length, whether at the surface or at the middle of the thickness, may be destroyed by proper adjustment of the points of support, and perhaps still more surely by supporting the bar at numerous points by lever-frames which will ensure equal supporting forces at all the points (a construction of which the theory has been treated by one of the members of the Committee), or in special experiments, by floating the bar in quicksilver. A second reason assigned by BESSEL is, that the principle of end-measure is more convenient than the line-measure for the production (that is, practically, the comparison) of copies of the standard. It appears probable that this remark is well founded, as regards the construction of secondary standards for commercial purposes, but it is doubtful whether it applies to secondary standards for scientific purposes, and it can scarcely apply to primary standards, in regard to which the consideration of convenience (in the few comparisons that may be made at intervals of many years) has no weight, when contrasted with the consideration of conservation of the standard length. Another reason is, that it is more convenient for use; but the members of the Committee, who have witnessed the operation of measuring a geodetic base by means of bars carrying the line-measure, have been led to form a high estimate of the convenience of the line-principle in that instance. It would appear, too, that in Captain KATER'S measurement of

* Darstellung der Untersuchungen und Maasregeln, welche in den Jahren 1835 bis 1838 durch die Einheit des Preussischen Längenmaasses veranlasst worden sind, von F. W. BESSEL, Berlin 1839.

the pendulum, and Mr. BAILY'S comparisons of the *mètre à traits* with the yard, no inconvenience from that cause was found by either observer. It is moreover to be remarked, that the whole of the British geodetic bases have been measured by bars constructed on the line-principle; and a standard which is intended to apply advantageously to them must be constructed on the same principle. The end-measure has never, so far as we know, been applied to any scientific determination in England.

“7. The construction of the ends of a standard formed on the end-principle (which must be made of materials harder than the rest of the bar, so mounted as to admit of a slight adjustment), is, in BESSEL'S construction, complicated and unsatisfactory; that of the ends of a standard on the line-principle is simple. The tendency of an end-standard to alter its length by wearing is in only one direction; that of a line-standard, so far as change can be conjectured, is matter of chance; it will however be practically invariable.

“8. A single comparison by end-measure is perhaps more accurate than a single comparison by line-measure. On the other hand, it seems doubtful whether this accuracy may not be impaired by the immersion in fluid which has been thought necessary for preventing unequal expansion. There has also been recognized in the line-measures which have been made in the course of these observations, a personal equation different with different observers; but this was only discovered after most of the observations were made. We have no evidence whether such equation exists in comparisons by end-measure, as the whole of the comparisons for the Prussian Standard were made by BESSEL himself. Still it is scarcely doubted that in this respect the system of end-measures has an advantage. On the other hand, there is no doubt that, by repeating the measures, and by varying the observers, the errors in line-measures arising from recognized causes will be eliminated, and unexceptionable accuracy will be given to the results.

“9. After consideration of all these points, as far as they were known at the time; remarking, in particular, the freedom of a line-standard from any tendency to constant wear, the applicability of a line-standard to our geodetic measures, the facility of comparing all other measures of a similar construction with a scale carefully subdivided, the circumstance that there exist no means of reproducing the old standard length but by reference to existing line-measures, and the historical fact that the British standard for many years past has been a line-standard; we decided on adopting a line-standard, or measure *à traits*, for the Parliamentary Standard of Length.

“10. The point which next engaged our attention was the material of which the new Standard of Length should be formed. The qualities required in the material are invariability and durability. Already we had reason to suspect that bars, which have received their form by undergoing while cold the violent mechanical operations of hammering, rolling, or drawing, will not preserve an invariable length; and these suspicions were raised to certainty by Mr. BAILY'S examination of the standard scale which *primâ facie* appeared to be the most trustworthy representative of the old Imperial

Standard, namely, the Royal Astronomical Society's drawn tubular scale. Remarking then, among the fusible metals and alloys, that copper is soft, and is not easily cast; that cast brass is considered unsound until it has been hammered; that gun-metal is easily cast, and may be made (by due proportion of its component metals) pretty hard and elastic, and is free from liability to corrosion; and that cast steel is perfectly manageable; remarking, also, that platinum, although it possesses the advantageous properties of being very durable, and little affected by change of temperature, is inconveniently heavy and soft; but that iron, whether cast or forged, is manageable, and probably invariable: we considered that our choice of materials was practically limited to the following metals and alloys:—

Gun-metal (in proportions of copper, tin, and zinc to be determined by experiment).

Cast Steel.

Cast Iron.

Forged Iron.

“11. A series of experiments was made by Mr. BAILY on gun-metal formed of different proportions of the simple metals. It was found at length that an alloy formed in the following proportions,—

Copper	16
Tin	$2\frac{1}{2}$
Zinc	1

appeared to possess every desirable property. It is hard; it is highly elastic, recovering its form (as to sense) perfectly after every strain, until the weight placed on it is sufficient to break it, when it breaks without bending; it is also strong.

“12. In the gun-metal above described, and in cast steel, and in cast or wrought iron, we were satisfied that we possessed materials for an *invariable* measure. In considering the question of *durability*, we could not fail to remark that bars of iron or steel are liable to rust; and that there is great danger of injury or even total destruction from this cause if the bars are inaccessible for many years or for centuries, or if, although accessible, they are very rarely examined. We at length decided on adopting, for the material of the Standards of Length, gun-metal composed in the proportions mentioned above.

“13. The form adopted for the Standard of Length and for all its copies is that of a solid square bar, 38 inches long and 1 inch square in transverse section. Near to each end a cylindrical hole is sunk (the distance between the centres of the two holes being 36 inches) to the depth of 0·5 inch. At the bottom of this hole is inserted in a smaller hole a gold plug or pin about 0·1 in diameter, and upon the surface of this pin there are cut three fine lines at intervals of about 0·01 inch transverse to the axis of the bar, and two lines at nearly the same interval parallel to the axis of the bar. The measure of length is given by the interval between the middle transversal line at one end and the middle transversal line at the other end; the part of each line which is employed being the point midway between the longitudinal lines. The other transversal lines were used, in the operations of comparison, only for assigning the scales of the micrometers.

“ 14. It was intended that the permanent rest of each bar, after the termination of the comparisons, should be upon a system of eight roller-cylinders, permitting the free thermal expansion of the bars, these rollers being carried by lever-frames, so arranged that the pressure received by each roller is necessarily one-eighth part of the whole weight of the bar, and the distances between the rollers being nearly those which are defined by the theory of the flexure of bars as proper to ensure that the measure between two lines (even if cut upon the surface of the bar) shall not be sensibly altered by the flexure of the bar. During the comparisons, however, the bars were floated in quicksilver.

“ 15. Under the direction of Mr. SHEEPSHANKS, and with our approval, the following apparatus was prepared for the comparison of the bars. A massive foundation of masonry was established in the cellar beneath the apartments of the Royal Astronomical Society, in the block of buildings east of the entrance-gateway of Somerset House. Upon one part of this foundation were supported stone piers and transoms, which carried the comparing microscopes. Upon another part there travelled a large carriage, bearing the trough of water which contained the trough of quicksilver in which the bars floated. It is not necessary here to describe the places of the thermometers, the contrivances for illuminating the divisions, &c. We desire, however, confidently to express our opinion, that no apparatus possessing equal firmness and delicacy with this, or ensuring equal immunity from irregular thermal expansion, had ever before been used for the comparison of standards *à traits*.

“ 16. The selection of authorities for the reproduction of the Imperial Standard was a matter of considerable difficulty. A careful collation of all the direct comparisons of different scales with the Imperial Standard, and of cross comparisons between the different scales, presented anomalies which it was impossible to explain. The scale which at a late date had been compared with greater care than any of the others, namely, the scale of the Royal Astronomical Society, was proved by Mr. BAILY to have undergone considerable change. This discovery necessarily took away all authority from other scales of a similar construction. The results obtained from SHUCKBURGH'S scale, according as KATER'S or BAILY'S measures are followed, are exceedingly discordant. Indeed, BAILY himself rejected the result of his own comparisons through SHUCKBURGH'S scale, as being quite incompatible with the result of direct comparisons with the Imperial Standard. After an elaborate examination of all these measures, Mr. SHEEPSHANKS arrived at these conclusions:—First, that no scales ought to be used for restoration of the value of the Imperial Standard, except those which had been compared *directly* with the Imperial Standard. Secondly, that among these the only admissible scales are, the Royal Society's brass scale No. 46, and the two 3-foot iron bars of the Ordnance Department. After examination of the reasons adduced by Mr. SHEEPSHANKS, we assented to these conclusions.

“ 17. The definition of a length, as represented by a standard bar, requires a statement of the temperature at which the standard bar is to be used. It appears, upon examining

the amount of the expansion of a metallic bar for a given change of temperature, that the effect of a change of $0^{\circ}\cdot 01$ or $0^{\circ}\cdot 02$ FAHRENHEIT is sensible in the measure of the length of a bar; and it was therefore necessary to employ methods of ascertaining the temperature, which should be certain to that degree of accuracy. No thermometer in England, at the time of commencing these experiments, could be trusted to such a nicety. Mr. SHEEPSHANKS, therefore, commenced his labours by forming a system of original thermometers; determining independently the freezing-point, the boiling-point, and the volume of every section of the tube of each. This process occupied a considerable time. To these new thermometers the thermometers employed in the former comparisons of the Imperial Standard with the Royal Society's scale and the Ordnance bars were referred, and the comparisons were reduced anew; and the relations between the lengths of the adopted authorities and the Imperial Standard were ascertained with all the accuracy which the comparative rudeness of construction of the Imperial Standard permitted. The thermometers to be used in the details of the new comparisons were also referred to the new thermometers; the thermometrical expansions of the various bars employed for the new standards, or of similar bars, for temperatures not differing materially from 62° FAHRENHEIT, were ascertained; and the whole of the thermometrical determinations were placed on a satisfactory basis.

“18. Very numerous comparisons were made by Mr. SHEEPSHANKS of the adopted authorities with bars which he called “Brass 2” and “Split-plug A” (the division or *trait* in the latter being not a cut on a flat face of metal, but the line produced by forcing two small surfaces of metal into contact, and then cutting by a transversal section through both pieces of metal; the section of the contact-plane then exhibits a delicate line). There were, however, discordances in the latter comparisons which prevented him from giving full confidence to the results. At length a better mode of illuminating the lines was devised, and then the whole of the preceding work was rejected, and new observations were begun. By means of these, the lengths of bars called Bronze 12 and Bronze 28 were determined in relation to the lost Imperial Standard, and the latter was used as a basis of reference for other bars.

“19. The Report of 1841 recommended (Article 5) that, besides the legal standard, there should be prepared four copies, to be deposited in places to be afterwards determined. Mr. SHEEPSHANKS therefore proceeded to make a series of comparisons of Bronze 28 with numerous bars, in order to select from them five bars which, in respect of the distinctness of their engraving, their floating evenly in quicksilver, and their near approach to the length of the lost Imperial Standard, might seem well adapted to be taken as Parliamentary Standard and Parliamentary Copies. When the observations had been carried to an extent which, it was supposed, would be perfectly satisfactory, it appeared that the results of comparison by different observers were sensibly different. An extensive series of new observations by numerous observers was at once commenced. The discussion of these observations showed clearly, as had been suspected before, that there is a difference among the results of different observers far exceeding the uncertainty

inferred by the theory of probable errors from the observations of each observer taken separately. Thus, in the comparisons of Bronze 10 with Bronze 28, there is a discordance between the results obtained by Mr. SHEEPHANKS from 142 sets of observations, and by Mr. WILLIAM SIMMS, junior, from 24 sets of observations, amounting (in ten-millionth parts of an inch) to 198; whereas the probable errors of the two determinations, deduced in the usual way from the observations of each observer separately, are only 15 and 26. In other words, each observer has a personal equation in the microscopic observation of the engraved lines. The existence of discordances of similar character between the astronomical observations of different observers has been long since recognized. The origin of this personal peculiarity is very obscure, but the fact seems to be beyond doubt. There appeared to be no proper method of treating the results but to take the means of the final results of the different observers, giving equal weight to each.

“20. The expansions of these bars corresponding to a given change of temperature had been sufficiently determined in the course of the experiments; and it was then judged expedient, instead of stating the difference in the length of the selected bars at the same temperature, to infer the difference of temperature which would cause all to represent the same length, by the application of which it would be possible to assign the specific temperature at which each bar represents precisely the length of one yard. Thus it was found that the length of one yard, as given by the lost Imperial Standard, is represented with no sensible uncertainty, except in the measures of the Imperial Standard itself, by the following bars, at the temperatures placed opposite to them:—

Bronze 19 or No. 1, at $62^{\circ}00$ FAHRENHEIT.

Bronze 20 or No. 2, at $61^{\circ}94$ FAHRENHEIT.

Bronze 2 or No. 3, at $62^{\circ}10$ FAHRENHEIT.

Bronze 7 or No. 4, at $61^{\circ}98$ FAHRENHEIT.

Bronze 10 or No. 5, at $62^{\circ}16$ FAHRENHEIT.

Bronze 28 or No. 6, at $62^{\circ}00$ FAHRENHEIT.

“21. The degrees of temperature for the use of these standards are defined as proportional to the corresponding apparent increase of volume of quicksilver in the thermometer-tube; the degree 32° representing the freezing-point of water; and the degree 212° representing the temperature of steam under LAPLACE'S standard atmospheric pressure, or the atmospheric pressure corresponding to the following number of inches in the barometric reading reduced to 32° FAHRENHEIT:—

$29.9218 + 0.0766 \times \text{cosine}(2. \text{latitude}) + 0.00000179 \times \text{height in feet above the sea};$

and the degree 62° denoting the temperature which produces in the quicksilver an apparent expansion equal to $\frac{30}{180}$ of the expansion between 32° and 212° ; and so in proportion for other degrees.

“23. We propose that the bar No. 1 be adopted by the Legislature as the PARLIAMENTARY STANDARD OF ONE YARD; that Nos. 2, 3, 4, 5 be adopted as Parliamentary Copies; and that No. 6 be retained by some officer of the Government for the comparison of

other bars, or for other scientific purposes in which reference to the Standard may soon be required. We will advert shortly to the proposed places of deposit of the Standards Nos. 1, 2, 3, 4, 5.

Places of Deposit of the Standards.

“ 32. It appears from the copy of the Bill of 1758, to which reference has been made, that the custody of the Standards by the Clerk of the House of Commons, which continued to the time of the destruction of the Houses of Parliament, was a matter of accident. It is recited in that Bill that the bar and the metallic weight, which it is proposed to adopt as legal standards (and which are described with sufficient accuracy to ensure their identity with the late Imperial Standards), together with their duplicates, are in the custody of the Clerk of the House of Commons; and it proposes to enact that “ the said standard Troy pound and the said standard yard shall on or before the 9th September 1765 be deposited and for ever remain in the Court of the Receipt of the Exchequer, and be there safely kept under the seals of the Chancellor of the Exchequer and of the Chief Baron, and the Seal of Office of the Chamberlains of the Exchequer, which seals shall not at any time be opened but by the order and in the personal presence of the Chancellor of the Exchequer and the Chief Baron for the time being, and then for the purposes only of guarding the same from all damage or injury, or of inspecting, examining, and comparing the copies and models hereinafter described, &c.” The Bill afterwards provides for the appointment of four commissioners, with clerks, workmen, &c., and for the establishment of a proper office; and that “ as soon as the said office shall be fixed and established, the said copies of the said standard yard and the said standard Troy pound, and the said models of parts and multiples, &c., shall be delivered to the said commissioners by the Clerk of the House of Commons, &c., and that one set shall be kept in the office under the seal of the Chief Baron of the Exchequer and the seals of the commissioners, and the other set shall be used for the purpose of sizing and adjusting, &c.” It appears that this subject had engaged the attention of the House of Commons in 1758 and 1759, and that the Bill above mentioned was introduced by Lord Carysfort in 1760, and had passed through committee; but in the pressure of business attending the death of George II., and the succession of George III., and the dissolution of Parliament soon following, it was not carried through all its stages. There appears, however, to be no doubt that the intention of the Committee of the House of Commons may be sufficiently gathered from the language of the Bill as cited above.

“ 33. Remarking this probable intention of the Legislature in the year 1760, and remarking also the evident propriety of placing the National Standards under the care of the Executive, we recommend that the Parliamentary Standards of One Yard and One Pound be deposited in the office of the Exchequer, there to be preserved under such regulations as to Parliament may appear fitting.

“ 34. In selecting places for the preservation of the authentic Copies of the Parliamentary Standards, we have been guided by a consideration of the general fitness of

the offices named; by an appreciation of the careful and accurate habits of the persons employed in them; by the limited accessibility to standards preserved in such offices, which it may be presumed will be made available for their legitimate purposes only; and by the occasional utility of accurate standards in verification of the operations to which these offices are devoted. We have in some measure departed from the recommendation contained in the last clause of Article 11 of the Report of 1841, December 21, in proposing that one set be transferred to the Royal Society of London. In this proposal we have been actuated by the considerations that the character of the Royal Society in every respect fits it for recognition as a depositary of scientific standards; that the first attempt in Britain to obtain an accurate standard of length, and the only attempt to secure a durable standard of weight, were made by that body; that it possesses at present a very valuable collection of standards; and that acknowledgment is due to it for its very important contribution to the means of restoring the value of the lost Standards. We adhere to the recommendation in Article 6 of the Report of 1841, that one set of copies should be imbedded in the masonry of a public building. In the distribution of the different copies, we have been guided by trifling peculiarities in the copies themselves.

“ 35. After careful consideration, we recommend,—

That the copy of Length Standard, No. 2, and the copy of Weight Standard, PC, No. 1, be deposited in the Royal Mint:

That the copy of Length Standard, No. 3, and the copy of Weight Standard, PC, No. 2, be transferred to the Royal Society:

That the copy of Length Standard, No. 5, and the copy of Weight Standard, PC, No. 3, be deposited in the Royal Observatory of Greenwich:

That the copy of Length Standard, No. 4, and the copy of Weight Standard, PC, No. 4, be immured in the cill of the recess on the east side of the Lower Waiting Hall in the New Palace at Westminster.

“ 36. We have to report, that, under the sanction of the Lords Commissioners of the Treasury, as conveyed by letter of Sir CHARLES E. TREVELYAN, dated 1853, June 23, and with the permission of the Commissioners of Public Works for immuring one set of standards in the masonry of the New Palace, as conveyed by letter of T. W. PHILIPPS, Esq., dated 1853, March 21, we have deposited the Standards and the several copies above named in the places specified above.

On the question of referring the Values of the Measure and Weight represented by the Standards to natural elements.

“ 40. After due consideration of this question, referring to the reasons explained in Chapter II. of the Report of 1841, December 21, we adhere to the recommendation contained in that chapter, and embodied in Articles 1 and 2 of the same Report, that no reference be made to natural elements for the values represented by the standards.

“ 41. We consider the ascertaining of the earth's dimensions and of the length of the seconds' pendulum in terms of the Standard of Length; and of the weight of a certain

volume of water in terms of the Standard of Weight, as philosophical determinations of the highest importance, to the prosecution of which we trust that Her Majesty's Government will always give their most liberal assistance; but we do not urge them on the Government at present as connected with the conservation of standards.

Derived Standards à bouts.

“44. We have already alluded (Article 6 above) to the value of length-standards *à bouts* for the ordinary uses of commerce; and from the commencement of our labours we have proposed to ourselves the formation of a standard *à bouts* equivalent in length to the Parliamentary Standard *à traits*, as necessary for the completeness of our undertaking. After consideration of the methods of verifying and using such a standard, we recommend that the metal be steel; and that the ends be hardened steel, or hard stone as quartz or sapphire, or some sufficiently hard and incorrodible material; and that the end surfaces be curved, forming portions of one sphere whose centre is the centre of the bar.

“45. At our request Mr. SHEEPHANKS has made preparations for forming such standards, to be compared with a steel Standard *à traits* whose length has been verified in the usual way by the Standard No. 6, to which reference is made in Article 20 above. We are not yet able to report the completion of these standards.”

The Lords Commissioners of the Treasury having adopted generally the recommendations of the Report, as applying to the Standard of Length and its Copies, a Bill was prepared and brought into Parliament, which received the Royal Assent on 1855, July 30. The Act is intituled “Anno decimo octavo et decimo nono Victoriae Reginae, Cap. LXXII. An Act for legalizing and preserving the restored Standards of Weights and Measures. [30th July 1855].”

The Preamble recites the provisions in the Act 5 Geo. IV. Cap. 74 for legalization and contingent restoration of the Standards; states the destruction of the Standards in the Fire of the Houses of Parliament; and then proceeds as follows (I have omitted various points relating to the Standard of Weight):—

“And whereas by the Researches of scientific Men Doubts were thrown on the Accuracy of the Methods provided by the said Act for the Restoration of the said Standards: And whereas there exist Bars which had been accurately compared with the said Standard Yard so destroyed as aforesaid, which afforded sufficient Means for restoring such original Standards: And whereas scientific Men acting for that Purpose under the Direction of the Commissioners of Her Majesty's Treasury have constructed a Standard of Length equivalent to the Imperial Standard Yard so destroyed, and Four accurate Copies of the Standard so constructed: And whereas the Form adopted for the Standard of Length and for all the Copies thereof is that of a solid square Bar Thirty-eight Inches long and One Inch square in transverse Section, the Bar being of Bronze or Gun Metal; near to each End a cylindrical Hole is sunk (the Distance between the Centres of the Two Holes being Thirty-six Inches) to the Depth of Half an Inch; at the Bottom of this Hole is inserted in a smaller Hole a Gold Plug or Pin about One

Tenth of an Inch in Diameter, and upon the Surface of this Pin there are cut Three fine lines at Intervals of about the One Hundredth Part of an Inch transverse to the Axis of the Bar, and Two Lines at nearly the same Interval parallel to the Axis of the Bar; the Measure of Length is given by the Interval between the Middle transversal Line at one End and the Middle transversal Line at the other End, the Part of each Line which is employed being the Point Midway between the longitudinal Lines; and the said Points are herein referred to as the Centres of the said Gold Plugs or Pins: And whereas the Standard of Length so constructed as aforesaid, the Bronze Bar, being marked "Copper 16 oz., Tin $2\frac{1}{2}$, Zinc 1. Mr. BAILY'S Metal. No. 1. Standard Yard at $62^{\circ}00$ FAHRENHEIT. Cast in 1845. TROUGHTON and SIMMS, London," and the said Standard of Weight marked P.S. 1844, 1 lb., have respectively been deposited in the Office of the Exchequer at *Westminster*, and One of the said Copies of the said Standard of Length, the Bronze Bar, being marked "Copper 16 oz., Tin $2\frac{1}{2}$, Zinc 1. Mr. BAILY'S Metal. No. 2. Standard Yard at $61^{\circ}94$ FAHRENHEIT. Cast in 1845. TROUGHTON and SIMMS, London," and One of the said Copies of the Standard of Weight marked No. 1, P.C. 1844, 1 lb., have been deposited at the Royal Mint; and One other of the said Copies of the Standard of Length, the Bronze Bar, being marked "Copper 16 oz., Tin $2\frac{1}{2}$, Zinc 1. Mr. BAILY'S Metal. No. 3. Standard Yard at $62^{\circ}10$ FAHRENHEIT. Cast in 1845. TROUGHTON and SIMMS, London," and One other of the said Copies of the Standard of Weight marked No. 2. P.C. 1844, 1 lb., have been delivered to the Royal Society of *London*; and One other of the said Copies of the Standard of Length, the Bronze Bar, being marked "Copper 16 oz., Tin $2\frac{1}{2}$, Zinc 1. Mr. BAILY'S Metal. No. 5. Standard Yard at $62^{\circ}16$ FAHRENHEIT. Cast in 1845. TROUGHTON and SIMMS, London," and One other of the said Copies of the Standard of Weight marked No. 3, P.C. 1844, 1 lb., have been deposited in the Royal Observatory of *Greenwich*; and the other of the said Copies of the Standard of Length, the Bronze Bar, being marked "Copper 16 oz., Tin $2\frac{1}{2}$, Zinc 1. Mr. BAILY'S Metal. No. 4. Standard Yard at $61^{\circ}98$ FAHRENHEIT. Cast in 1845. TROUGHTON and SIMMS, London," and the other of the said Copies of the Standard of Weight marked No. 4. P.C. 1844, 1 lb., have been immured in the Cill of the Recess on the East Side of the Lower Waiting Hall in the New Palace at *Westminster*: And whereas it is expedient to legalize the Standards so constructed and to provide for the Preservation thereof: Be it therefore enacted by the Queen's most Excellent Majesty, by and with the Advice and Consent of the Lords Spiritual and Temporal, and Commons, in this present Parliament assembled, and by the Authority of the same, as follows:

"I. So much of the said Act of the Fifth Year of King *George* the Fourth as relates to the Restoration of the Imperial Standard Yard and of the Standard Troy Pound respectively, in case of Loss, Destruction, Defacement, or other Injury, shall be repealed.

"II. The straight Line or Distance between the Centres of the Two Gold Plugs or Pins in the Bronze Bar deposited in the Office of the Exchequer as aforesaid shall be the genuine Standard of that Measure of Length called a Yard, and the said straight

Line or Distance between the Centres of the said Gold Plugs or Pins in the said Bronze Bar (the Bronze being at the Temperature of Sixty-two Degrees by FAHRENHEIT'S Thermometer) shall be and be deemed to be the Imperial Standard Yard.

“VII. If at any Time hereafter the said Imperial Standard Yard and Standard Pound Avoirdupois respectively, or either of them, be lost, or in any Manner destroyed, defaced, or otherwise injured, the Commissioners of Her Majesty's Treasury may cause the same to be restored by Reference to or Adoption of any of the Copies so deposited as aforesaid, or such of them as may remain available for that Purpose.”

I have now only to give the new nomenclature of the Bars and the temperatures at which they represent the British Yard; and a statement of their distribution up to the present time (1857, April).

Old Name of Bar.	New Number.	Standard Temperature.	Distribution of Bars.
Bronze 19	1	62·00	NATIONAL STANDARD, at the Exchequer, in the custody of the Right Honourable the Comptroller of the Exchequer. Parliamentary Copy, at the Royal Mint. Parliamentary Copy, in charge of the Royal Society. Parliamentary Copy, immured in the New Palace, Westminster. Parliamentary Copy, at the Royal Observatory, Greenwich.
Bronze 20	2	61·94	
Bronze 2	3	62·10	
Bronze 7	4	61·98	
Bronze 10	5	62·16	
Bronze 28	6	62·00	Retained at the Royal Observatory, as accessible representative of the National Standard.
Bronze 1	7	61·78	To the East India Company.
Bronze 8	8	61·82	To the Government of Russia.
Bronze 9	9	61·25	To the Government of Prussia.
Bronze 4	10	61·51	To the Government of Bavaria.
Bronze 11	11	61·79	To the Government of the United States of America.
Bronze 12	12	61·80	At the Royal Observatory, Greenwich, still disposable.
Bronze 13	13	61·86	To the Government of Austria.
Bronze 14	14	61·59	To the Municipality of Edinburgh.
Bronze 15	15	62·31	To the Municipality of Dublin.
Bronze 16	16	61·94	To the Colony of Canada.
Bronze 17	17	62·14	To the Colony of the Cape of Good Hope.
Bronze 18	18	62·26	To the Colony of New South Wales.
Bronze 5	19	61·95	To the Government of Portugal.
Bronze 3	20	62·23	To the Government of Spain.
Bronze 21	21	61·80	To the Government of France.
Bronze 22	22	61·75	To the Government of Belgium.
Bronze 23	23	61·77	To the Government of Holland.
Bronze 24	24	61·68	To the Government of Hanover.
Bronze 25	25	61·97	To the Government of Saxony.
Bronze 26	26	61·47	To the Government of Sweden.
Bronze 27	27	61·81	To the Government of Denmark.
Bronze 6	28	61·73	To the Government of Switzerland.
Bronze 29	29	61·51	To the Ordnance Map Office.
Bronze 30	30	61·66	At the Royal Observatory, Greenwich, still disposable.
Bronze 31	31	62·04	To William Simms, Esq.
Bronze 32	32	62·04	To the Government of Sardinia.
Bronze 33	33	61·92	To the Government of the Papal States.
Bronze 34	34	62·03	To the Government of Naples and Sicily.
Bronze 35	35	61·95	To the Government of Turkey.
Bronze 36	36	62·08.	To the Government of Brazil.
Bronze 37	37	62·07	To the Colony of Tasmania.

Table (continued).

Old Name of Bar.	New Number.	Standard Temperature.	Distribution of Bars.
Bronze 38	38	62·14	To the Government of Buenos Ayres.
Bronze 39	39	61·87	To the Government of Chili.
Bronze 40	40	61·99	To the Colony of Victoria.
BAILY'S A	41	62·37	} At the Royal Observatory, Greenwich, still disposable.
BAILY'S B	42	61·67	
BAILY'S C	43	61·57	
BAILY'S D	44	61·68	
Brass 1	46	61·99	} At the Royal Observatory, Greenwich, still disposable.
Brass 2	47	61·14	
Flat Brass Scale.....	48	62·00	
Kew Bar.....	49	61·84	
New Tubular Scale ...	50	63·09	To the Kew Observatory. At the Royal Observatory, Greenwich, still disposable.
DONKIN'S Copper	51	61·87	} At the Royal Observatory, Greenwich, still disposable.
MAUDSLAYS' Copper...	52	61·82	
MAY'S Alloy	53	61·53	
Swedish A	54	63·55	To the Government of Bavaria.
Swedish B	55	61·93	To the Ordnance Map Office.
Swedish C	56	61·77	To the Government of Russia.
Low Moor A	57	62·58	To the Government of the United States of America.
Low Moor B	58	61·92	At the Royal Observatory, Greenwich, still disposable.
Low Moor C	59	61·65	To the East India Company.
Low Moor D	60	61·79	To the Government of Prussia.
Cast Iron A	61	62·56	} At the Royal Observatory, Greenwich, still disposable.
Cast Iron B	62	62·90	
Cast Iron C	63	62·34	
Cast Iron D	64	62·63	To the Government of Austria.
Cast Steel A	65	62·22	} At the Royal Observatory, Greenwich, still disposable.
Cast Steel B	66	62·11	
Cast Steel C	67	62·47	
Cast Steel D	68	62·62	To the Académie des Sciences of Paris.
End-bars.			
Bronze	69	61·67	} At the Royal Observatory, Greenwich, still disposable.
Swedish A	70	62·07	
Low Moor A	71	62·01	
Cast Steel	72	62·03	To Joseph Whitworth, Esq.
Cast Steel	73	61·96	} At the Royal Observatory, Greenwich, still disposable.
Bronze	74	61·91	
Bronze	45	62·19	
Old Scales.			
BAILY'S Tubular 5.....	59·97	} These have never been the property of the British Government.
SIMMS'S Tubular 4	60·55	
R. Ast. Soc. Tubular	60·78	
Danish Tubular.....	60·74	

In addition to these there are,—No. 75, an undivided bar, marked by mistake: Nos. 76, 77, 78, one-foot end-bars; Nos. 79, 80, six-inch end bars: and Nos. 81, 82, three-inch end-bars: intended for secondary comparison at the Exchequer or other offices, but at present lodged at the Royal Observatory.

The Documents of every kind, relating to the Standard Commissions and the preparation of Standards, are preserved at the Royal Observatory, Greenwich.

1857, April 8.

G. B. AIRY.

ADDENDUM.

Since the preparation of this paper, the following bars have been lodged in the Exchequer Office of Weights and Measures, for use:—

Line-Bar	No. 30.
	} No. 70. No. 45. No. 76. No. 79. No. 81.
End-Bars	

1858, *February* 19.

G. B. AIRY.

Note on the Tubular Scale of the Royal Astronomical Society.

The information which the Committee possessed as to the discordance in the relative lengths of the intervals *Aa*, *Bb*, *Cc*, *Dd*, on this scale, as ascertained at different times (to which allusion is made in page 645), was derived from Mr. BAILY's letters, and from an Abstract entered by Mr. BAILY himself in his manuscript book of observations. On careful examination of those observations, in the course of reading the proof-sheets of this Account, it was found that Mr. BAILY had given all the signs erroneously, for the observations of 1844, April 21. The signs as now printed in page 645 are correct. On examining into the effect of this change, it will be seen that the discordance is really far less than it was supposed to be by Mr. BAILY; and that the Tubular Scale merits greater credit than it obtained with the Committee and Mr. SHEEPHANKS.

1858, *March* 3.

G. B. AIRY.

Fig. 1.

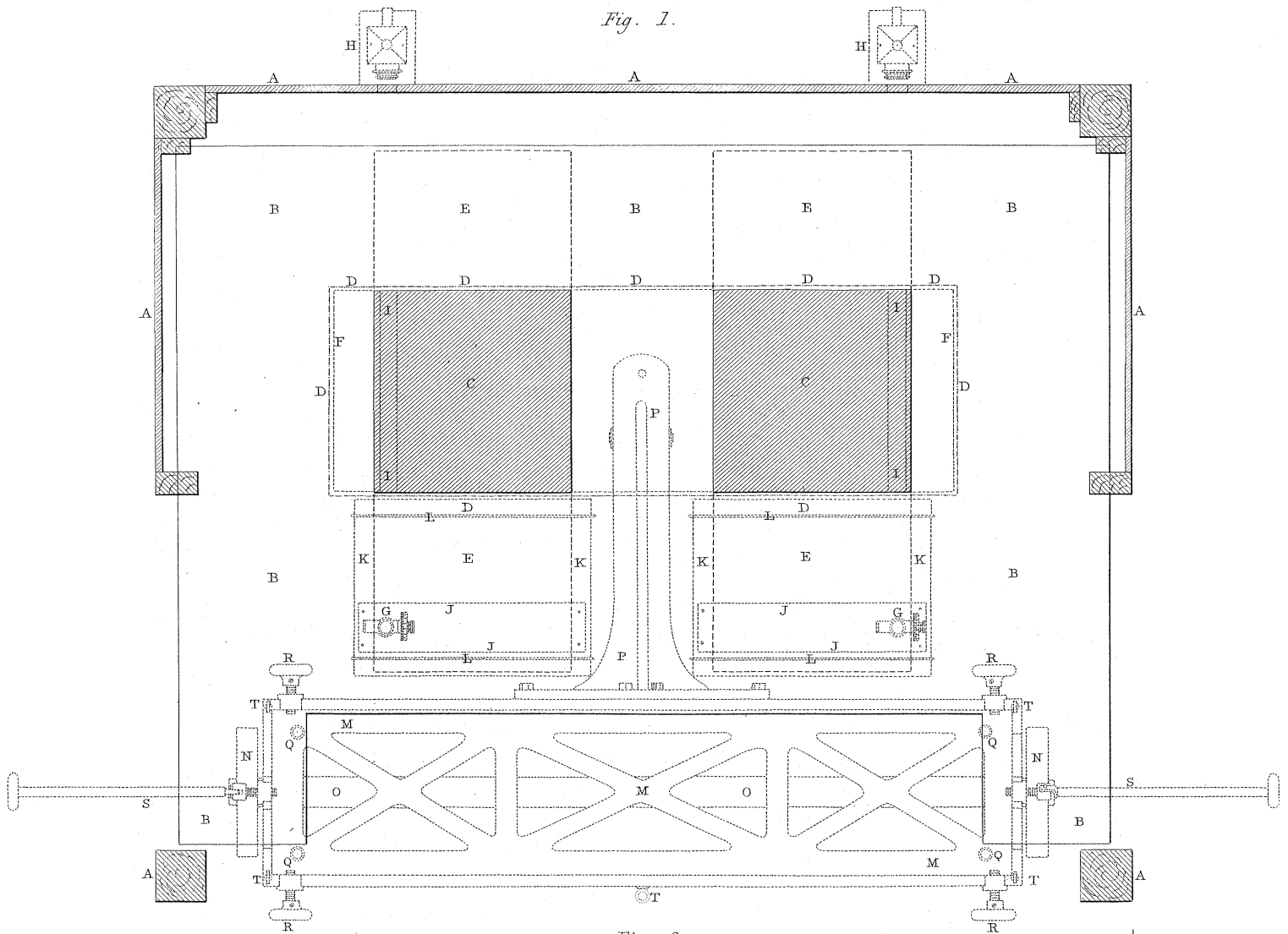
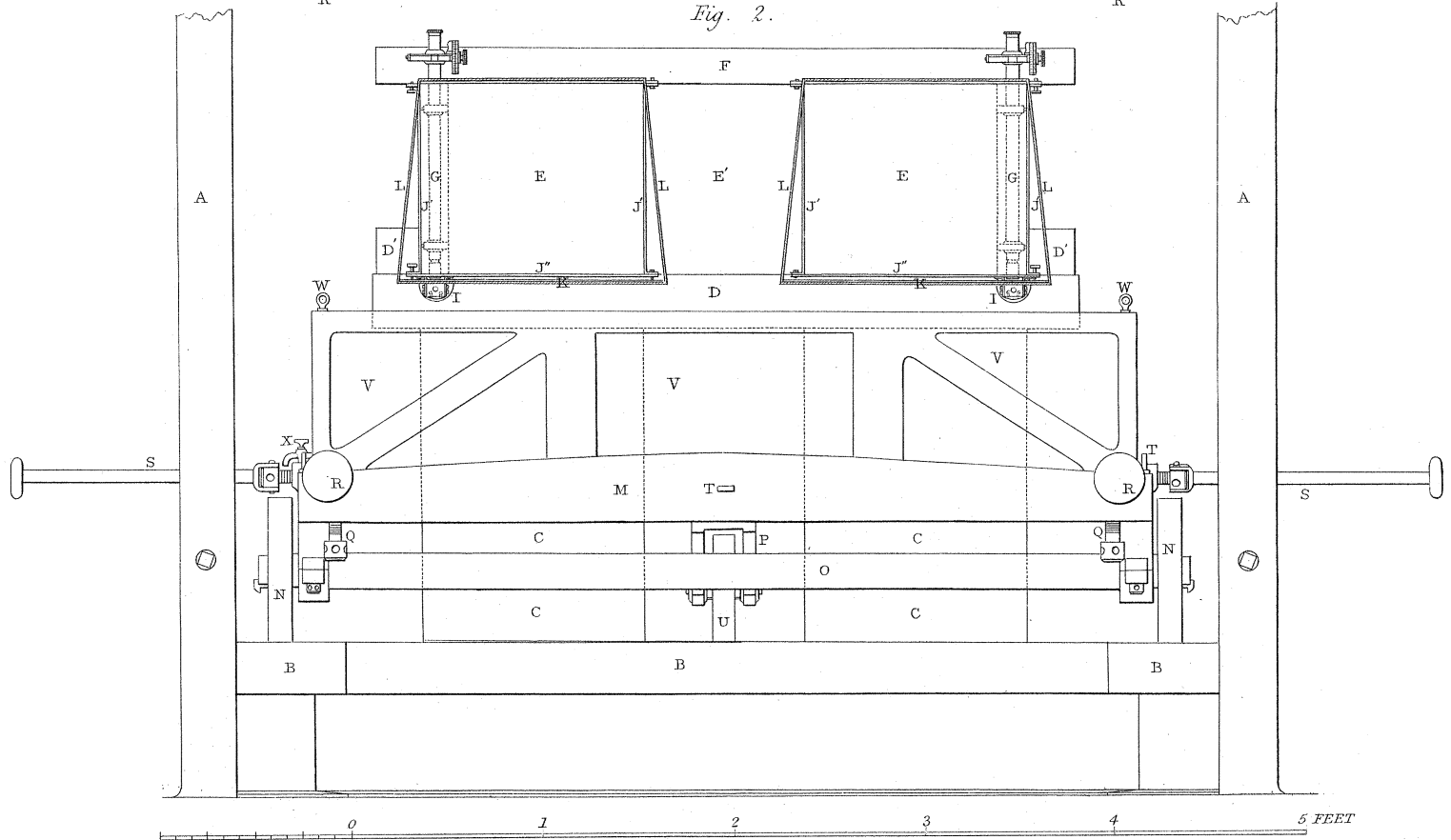

Fig. 2.



0 1 2 3 4 5 FEET

Fig. 3

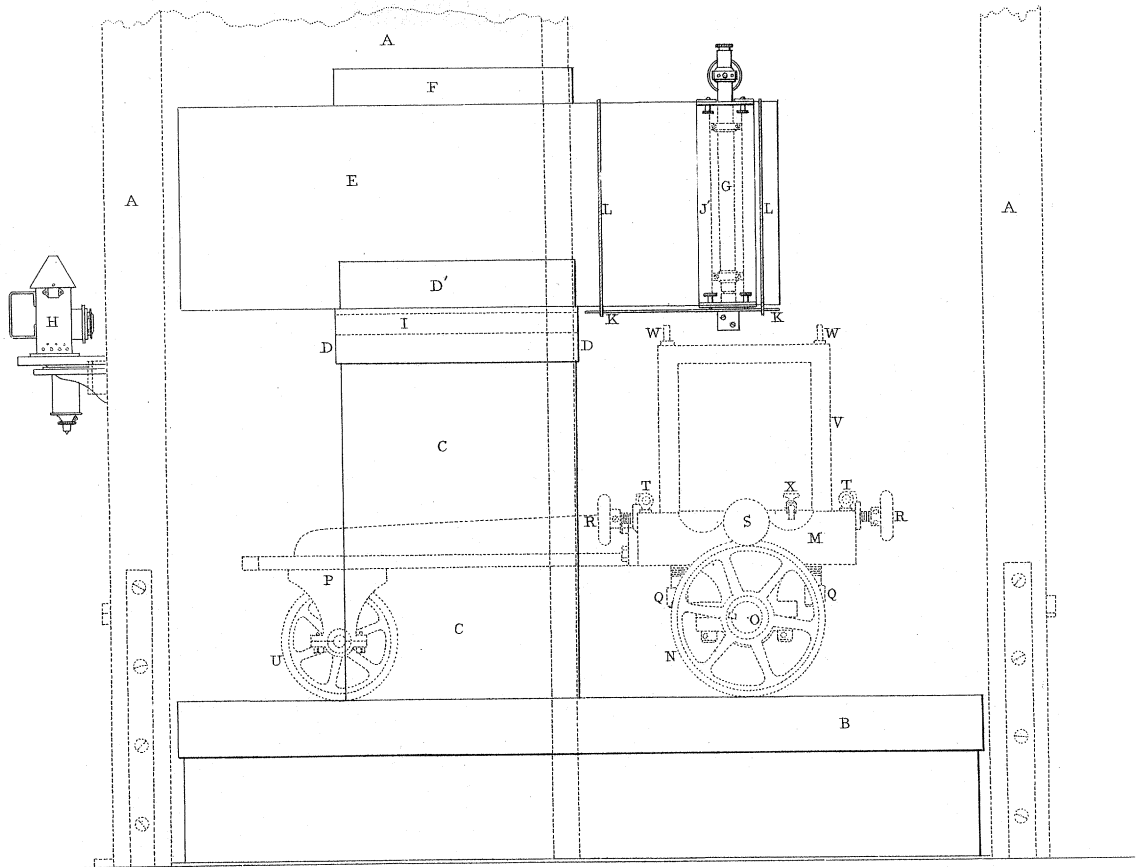

Fig. 4.

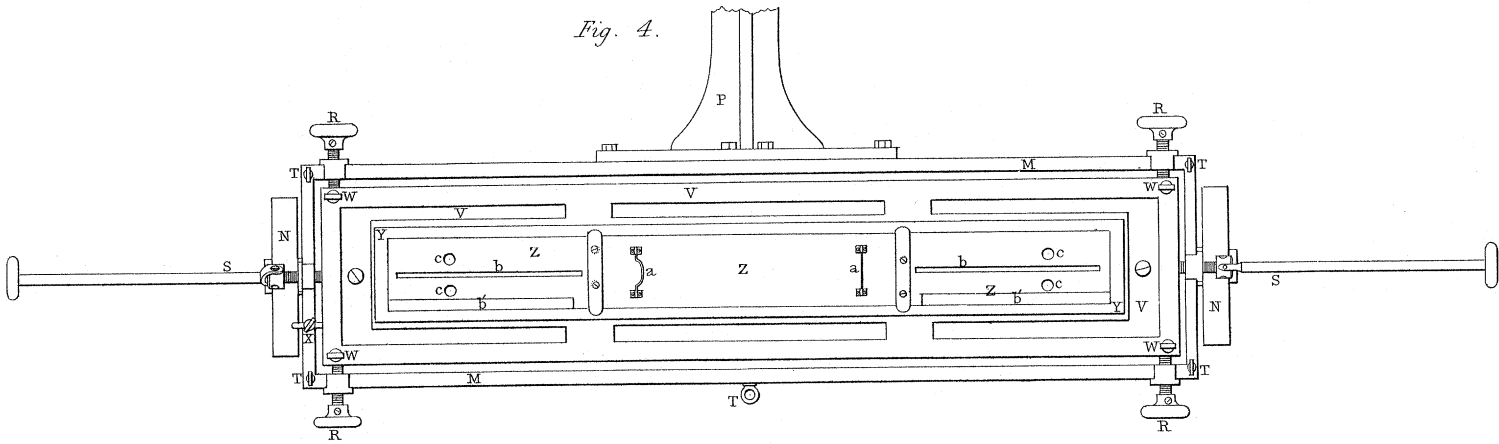

Fig. 5.

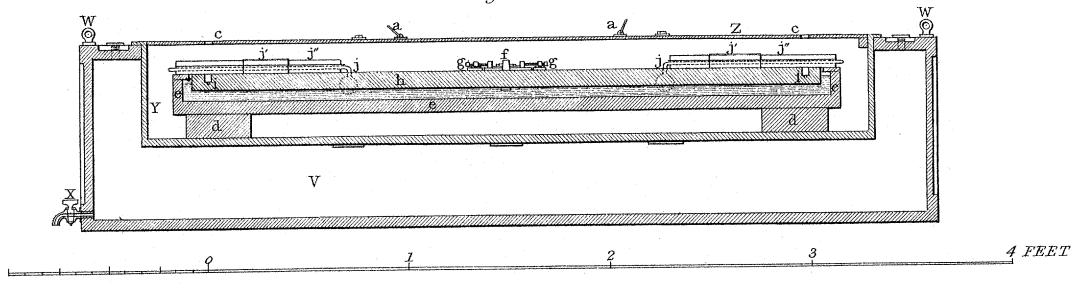

Fig. 6.

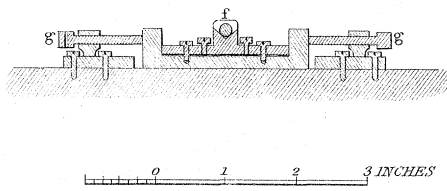

Fig. 7.

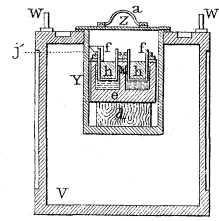

Fig. 8.

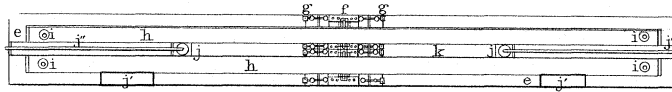

Fig. 9.

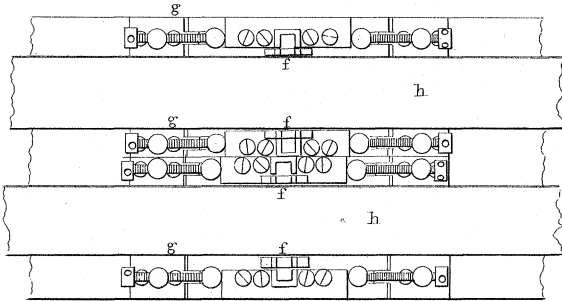

Fig. 13.

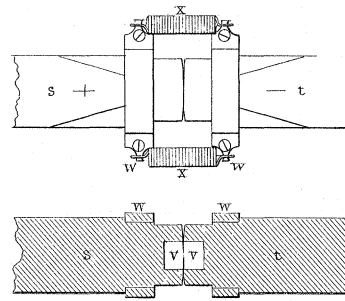

Fig. 14.

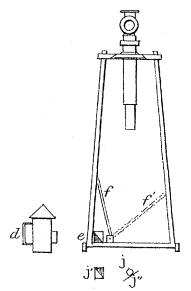

Fig. 10.

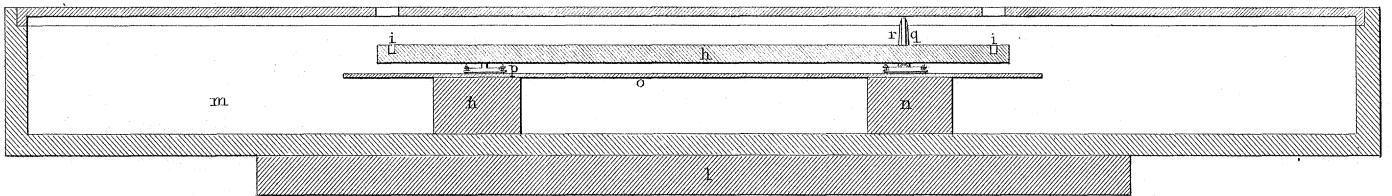

Fig. 11.

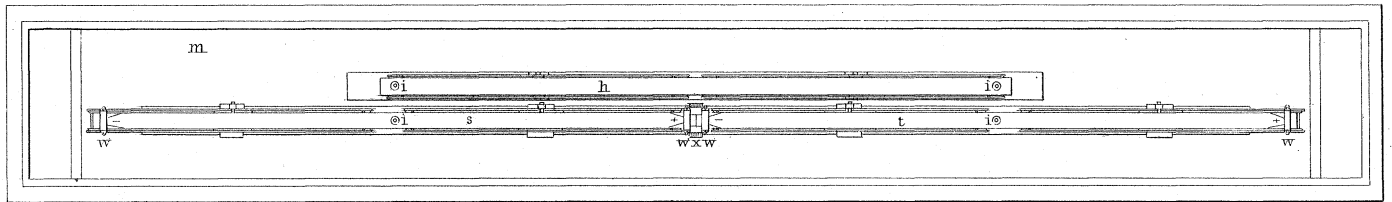

Fig. 12.

